



ÄNDRING AV DETALJPLAN FÖR KV FJÄRILEN M FL (Söderby III)

i Salem, Salems kommun, Stockholms län

Plan nr 82-71, tillägg till gällande detaljplan nr 82-03, dnr 2006/723

TYPRITNINGAR FÖR RADHUS BILAGA TILL PLANBESKRIVNINGEN

Upprättad 2008-03-25 av plan- och exploateringsenheten, rev 2008-05-16

RITNINGSFÖRTECKNING

Obs ritningarnas skala kan variera något.

För vilken hustyp som finns i hustyper i respektive länga, se planbestämmelserna.

beteckning	dat	innehåll	gäller för hustyp/-er			
			Br	Cr	Dr	Er
Br 2	2008 03 17	inglasat uterum höger	x			
Br-3	2008 03 17	inglasat uterum vänster	x			
Cr-2	2008 05 16	inglasat uterum höger		x		
Cr-3	2008 05 16	inglasat uterum vänster		x		
Dr-6	2008 03 13	inglasat uterum höger			x	
Er-4	2008 03 17	inglasat uterum vänster				x
K-1	2005 06 09	takfot vinklad	x	x	x	x
K-2	2006 08 21	takfot rak	x	x	x	x
Dr-3	2008 05 16	burspråk 1,80 baksida			x	
K-3	2008 05 16	burspråk 0,80	x	x	x	x
K-4	2008 05 16	burspråk 1,80 m entretak	x	x		x
K-5	2008 05 16	burspråk 1,80 m farstukvist	x	x		x
K6	2008 05 16	inbyggd farstukvist	x	x	x	x
K7	2008 03 17	entrétak sadel, pulpet	x	x	x	x
K-8	2008 03 17	balkong rak		x	x	
K-9	2008 05 16	balkong fasade hörn		x	x	
K-10	2008 03 17	balkong vinkel		x	x	

På hustyp Dr: inglasat uterum (baksida) *eller* burspråk (kök)

På hustyp Br, Cr, Er: Inbyggd farstukvist (K6) eller entrétak (K7) kan kombineras med litet burspråk (K-3) men ej med djupt burspråk (K-4). Önskas både inbyggd farstukvist och stort burspråk välj den kombinerade typritningen (K-5).

Alla väggar i burspråk och inbyggda farstukvistar skall utföras i lägst brandklass EI 30.

FJÄRILEN

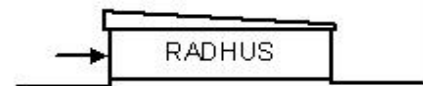
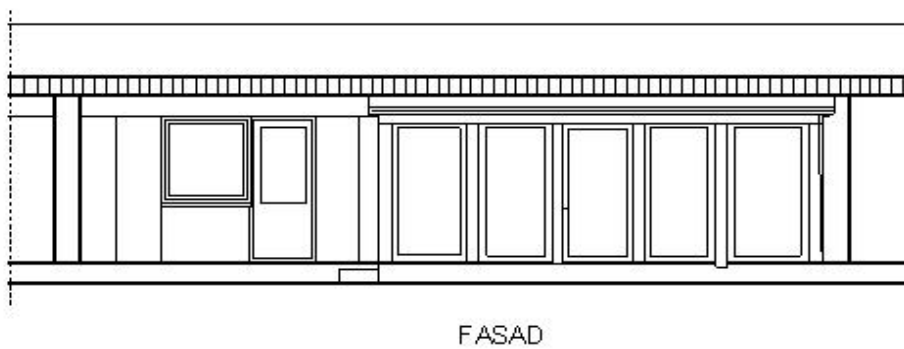
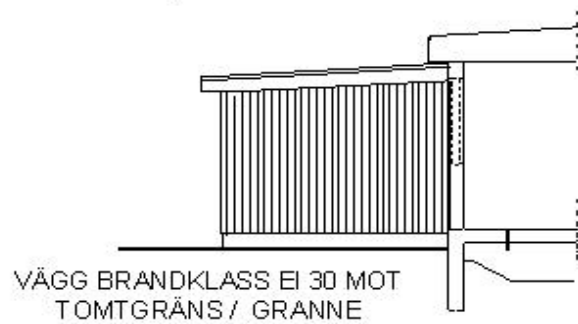
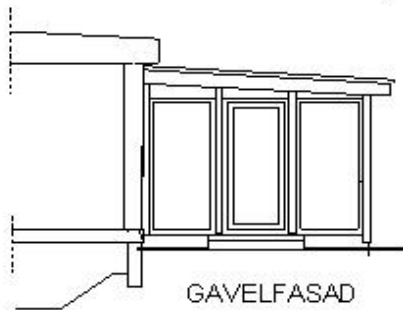
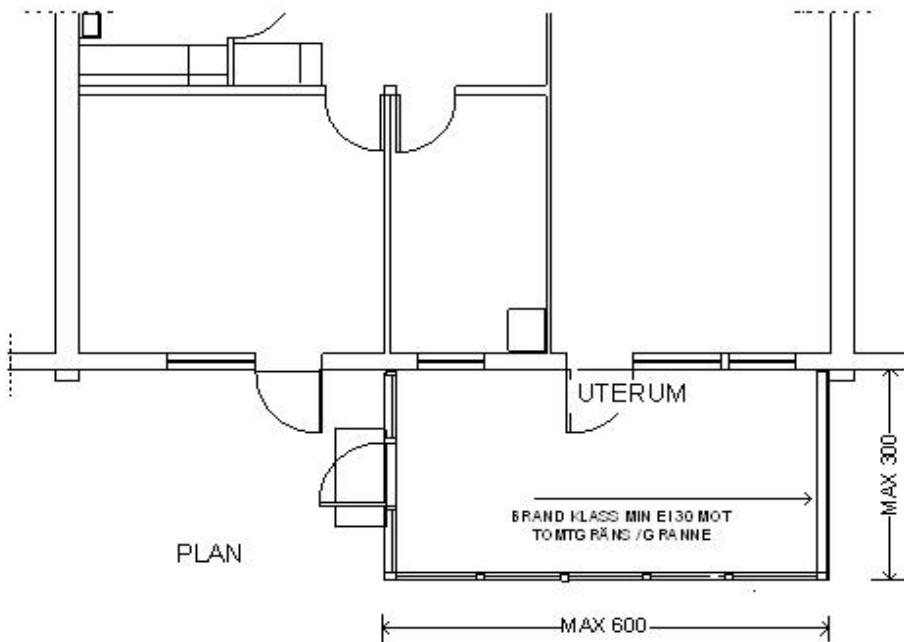

REV 2008 03 17

SALEMS KOMMUN

HUSTYP Br STORT INGLASAT UTERUM

FASTIGHET:

PLAN, FASADER

ADRESS:

SKALA 1:100

DATUM:

Br-2

FJÄRILEN

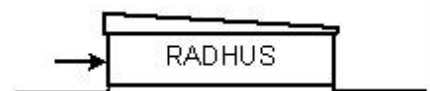
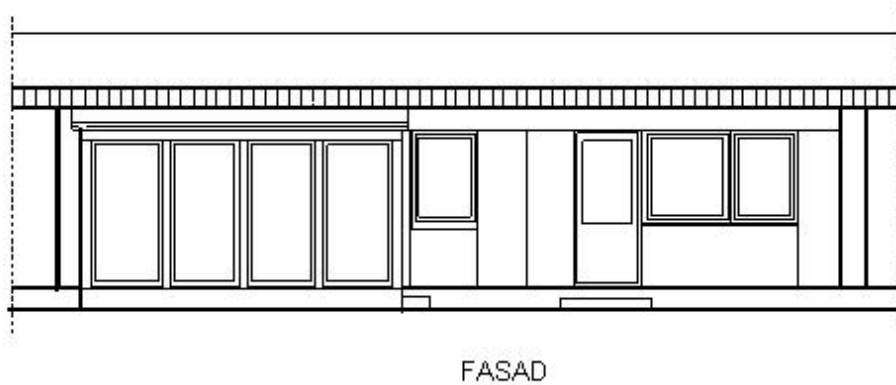
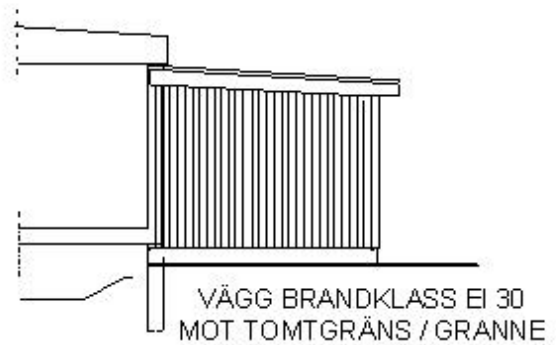
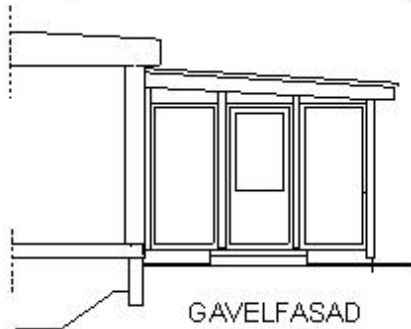
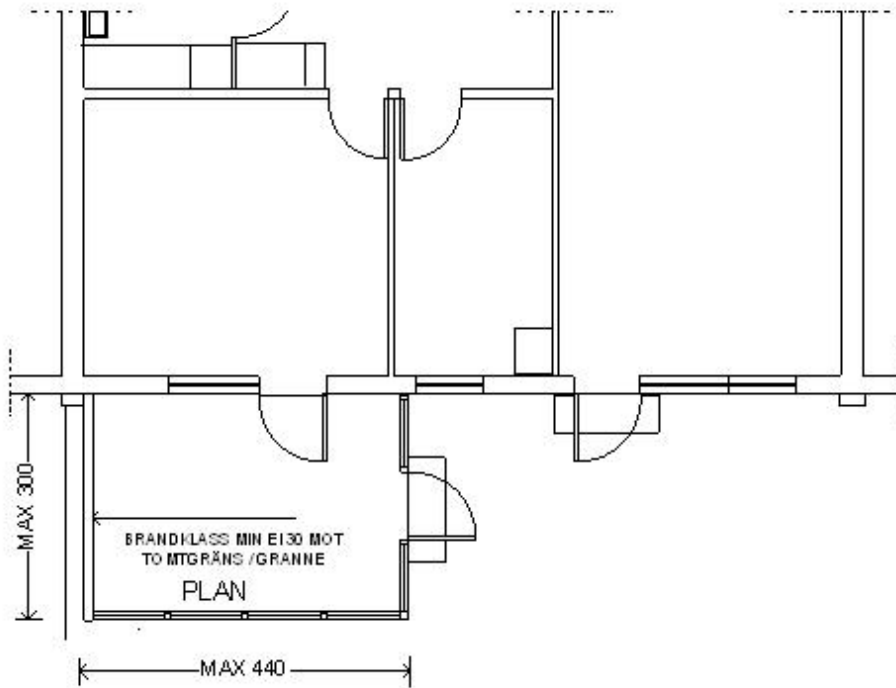

REV 2008 03 17

SALEMS KOMMUN

HUSTYP Br

INGLASAT UTERUM HELGLAS

FASTIGHET:

PLAN, FASADER

ADRESS:

SKALA 1:100

DATUM:

Br-3

FJÄRILEN

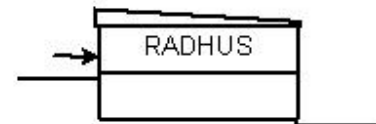
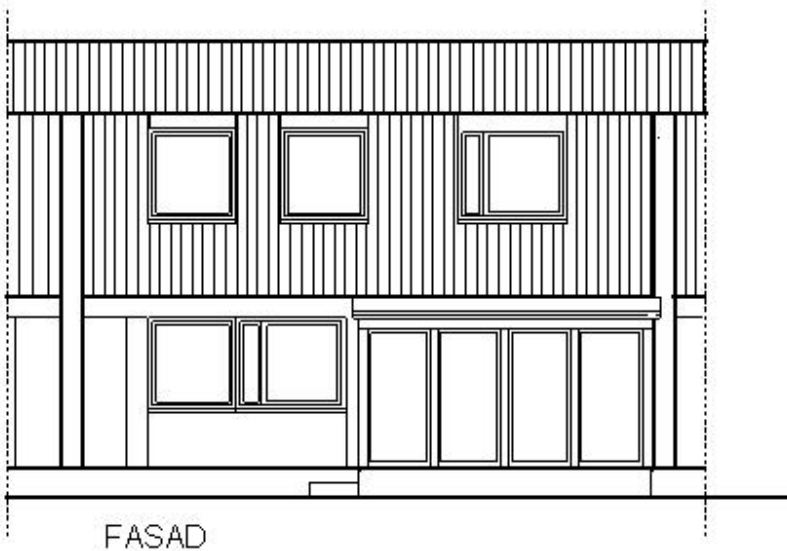
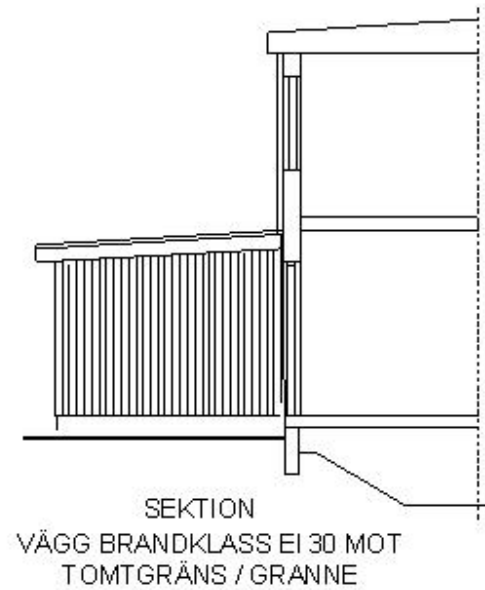
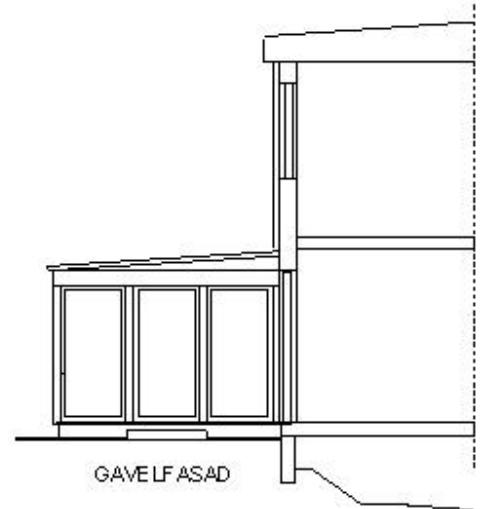
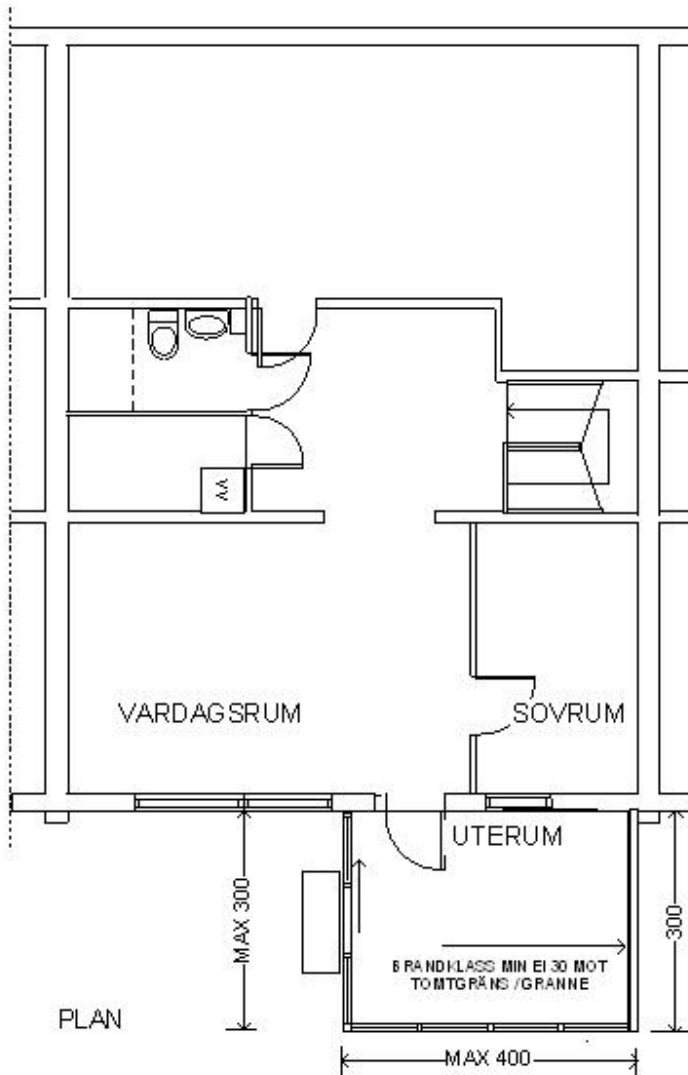

REV 2008 05 16

SALEMS KOMMUN

HUSTYP Cr

INGLASAT UTERUM

FASTIGHET:

PLAN, FASADER

ADRESS:

SKALA 1:100

DATUM:

Cr-2

FJÄRILEN

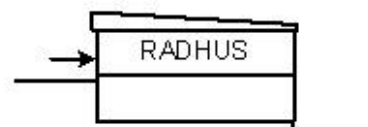
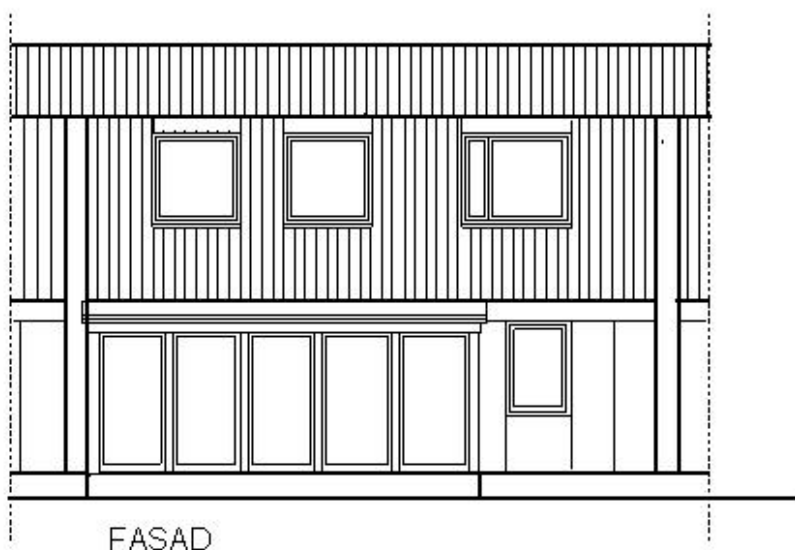
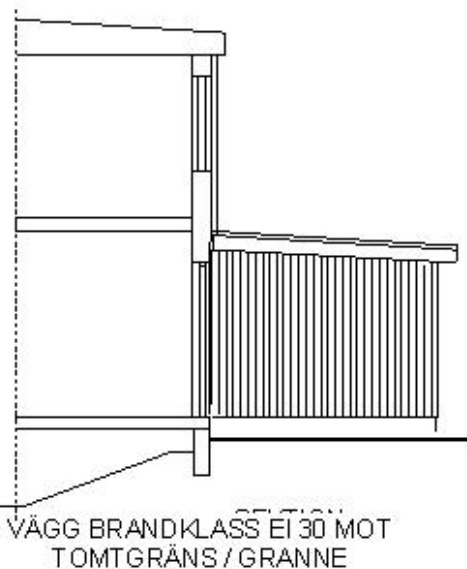
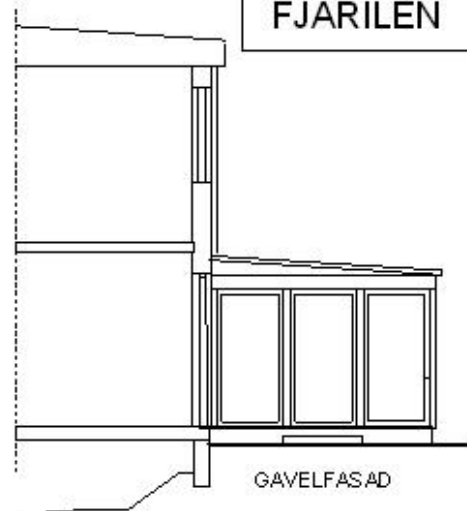
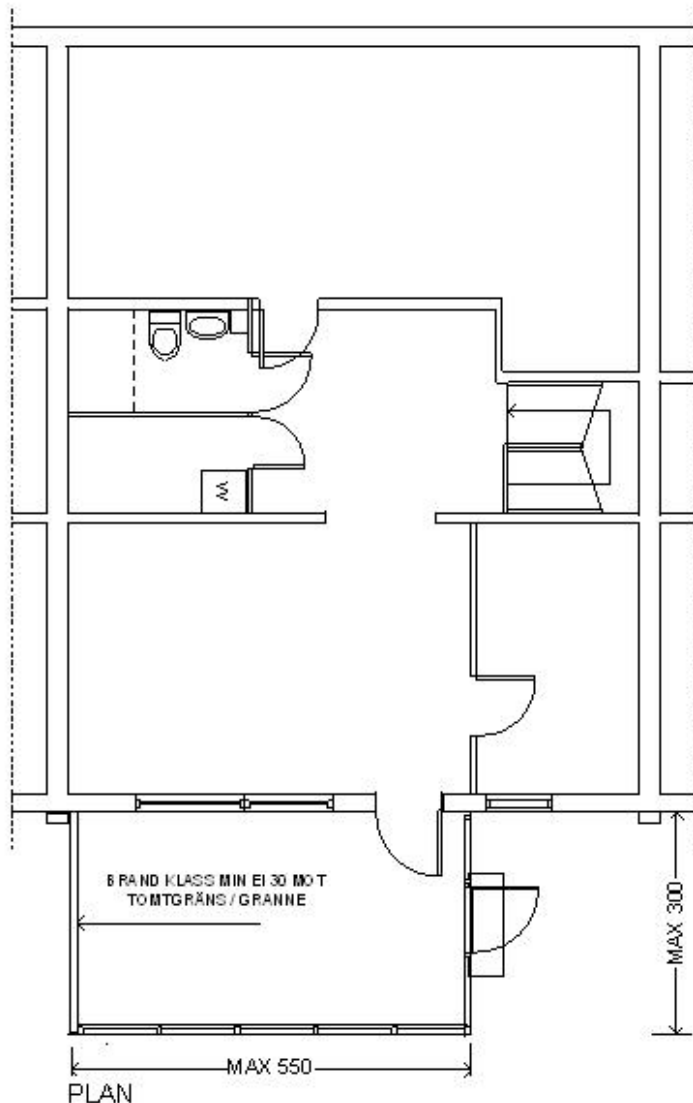

REV 2008 05 16

SALEMS KOMMUN

HUSTYP Cr

STORT INGLASAT UTERUM

FASTIGHET:

PLAN, FASADER

ADRESS:

SKALA 1:100

DATUM:

Cr-3

FJÄRILEN

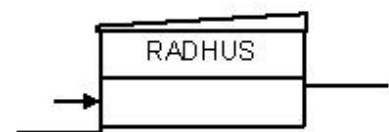
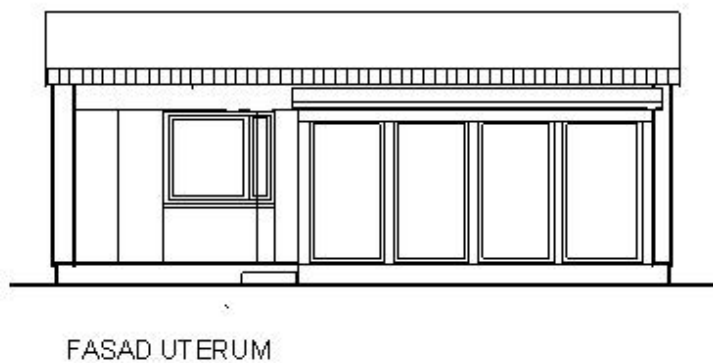
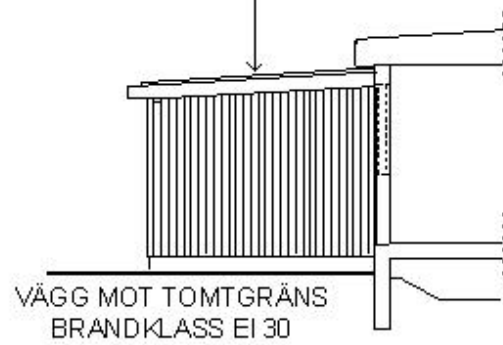
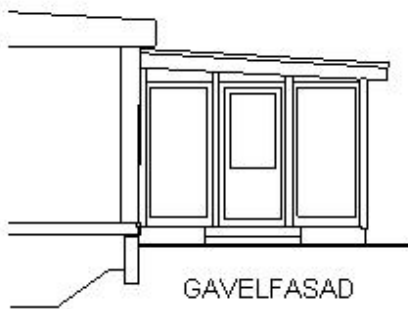
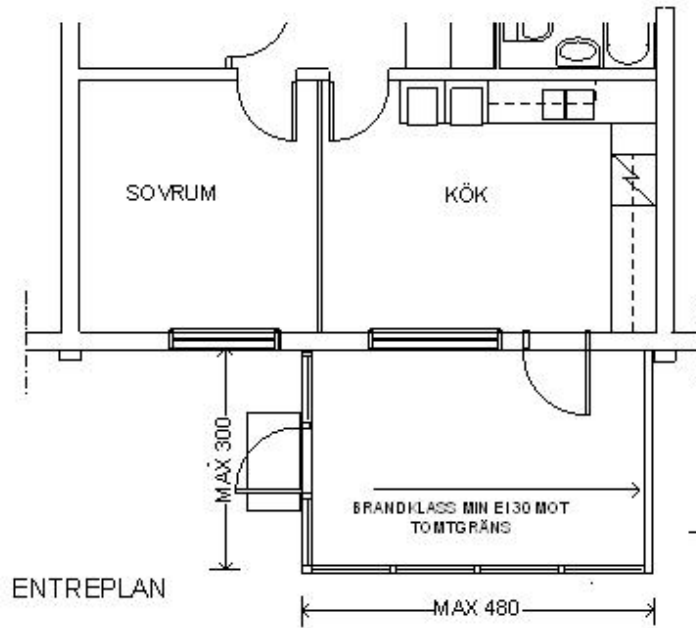

REV 2008 03 17

SALEMS KOMMUN

HUSTYP DK

INGLASAT UTERUM, HELGLAS

FASTIGHET:

PLAN, FASADER

ADRESS:

SKALA 1:100

DATUM:

Dr-6

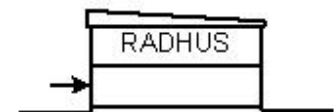
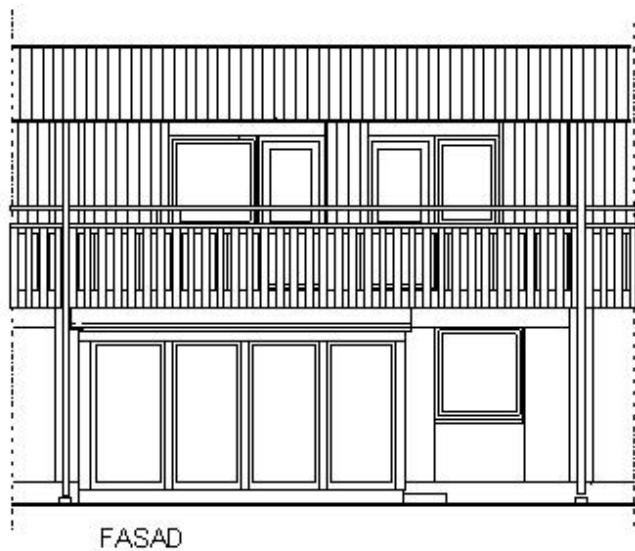
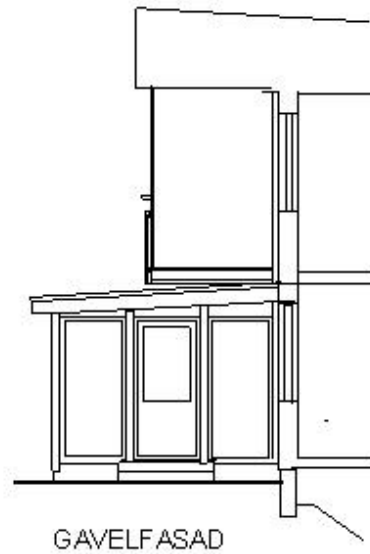
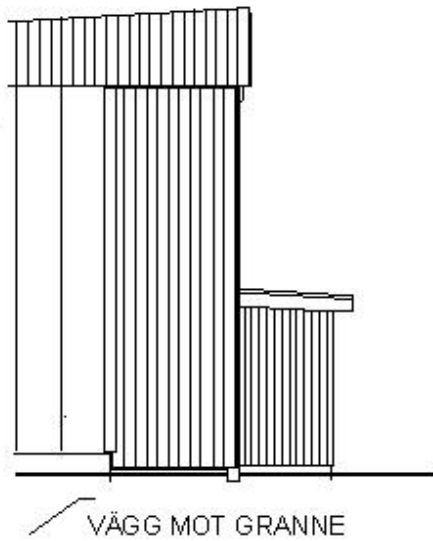
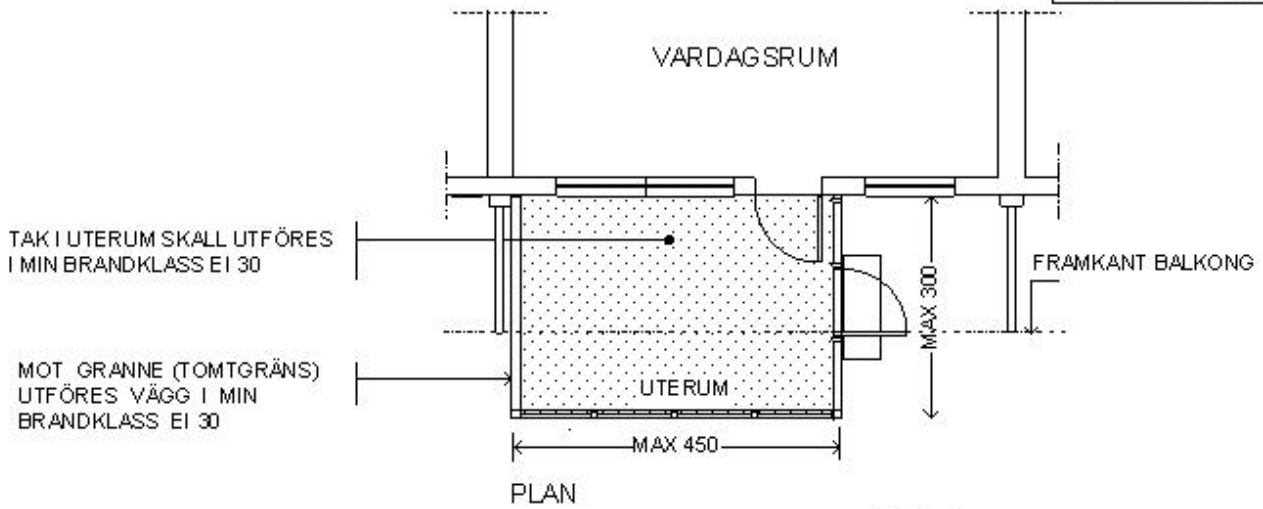

REV 2008 03 17

SALEMS KOMMUN

HUSTYP Er INGLASAT UTERUM HELGLAS

FASTIGHET:
ADRESS:

PLAN, FASADER
SKALA 1:100

DATUM:

Er-4

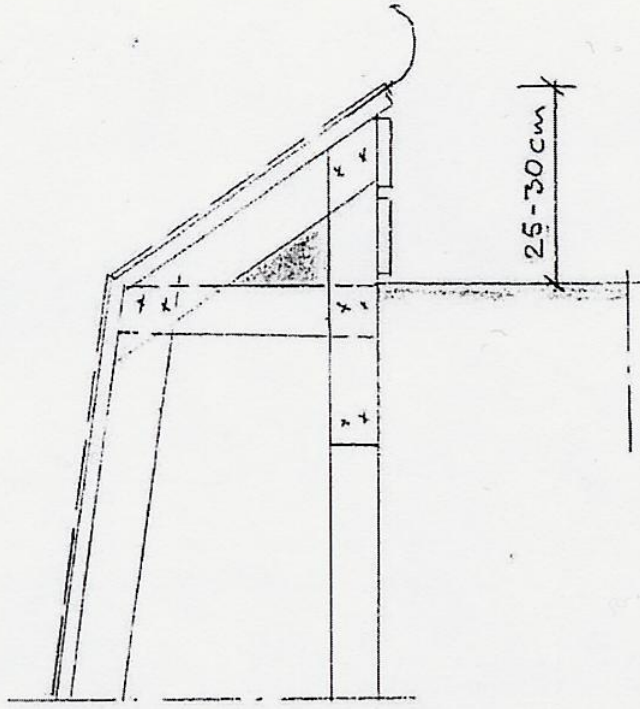
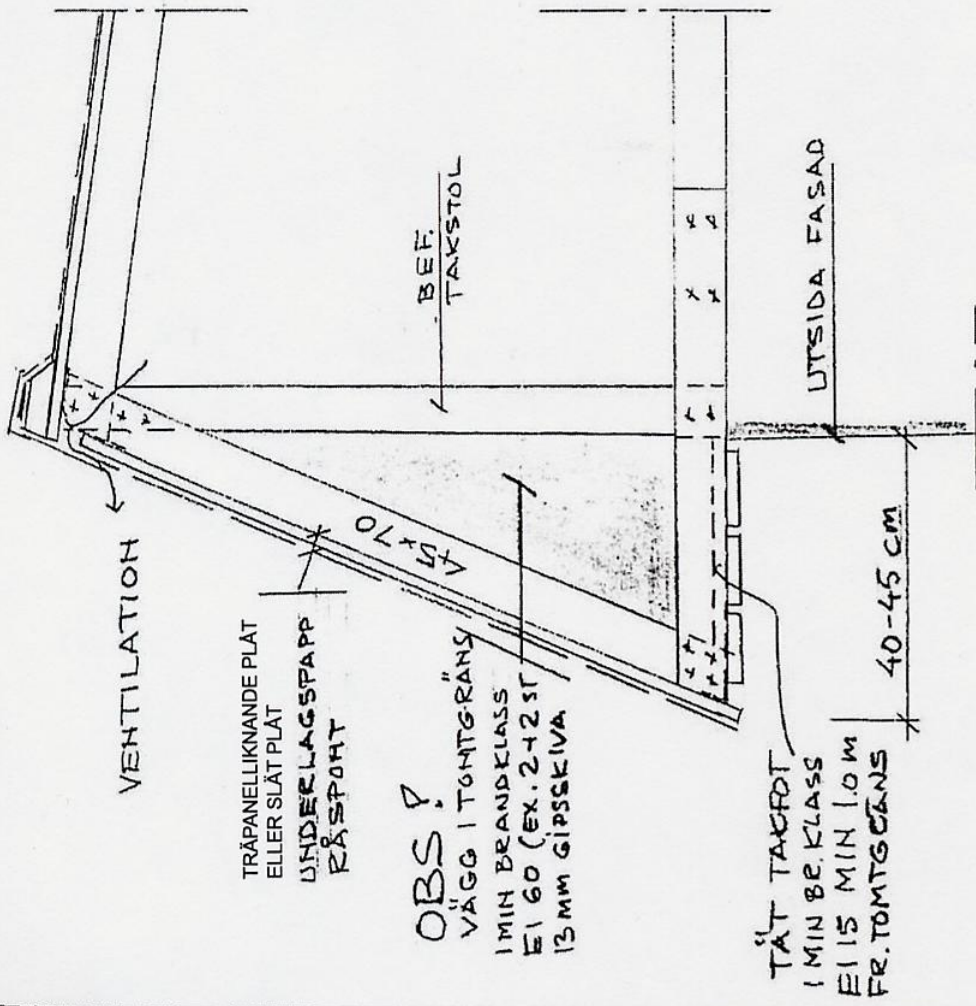

SALEM

OMBYGGNAD AV TAKROT
TYPSEKTIONER I SKALA 1:10
2005-06-09

Kjell Nilsson
KJELL NILSSON

K-1

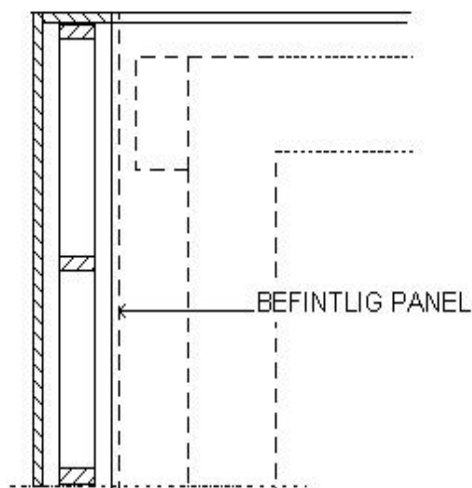
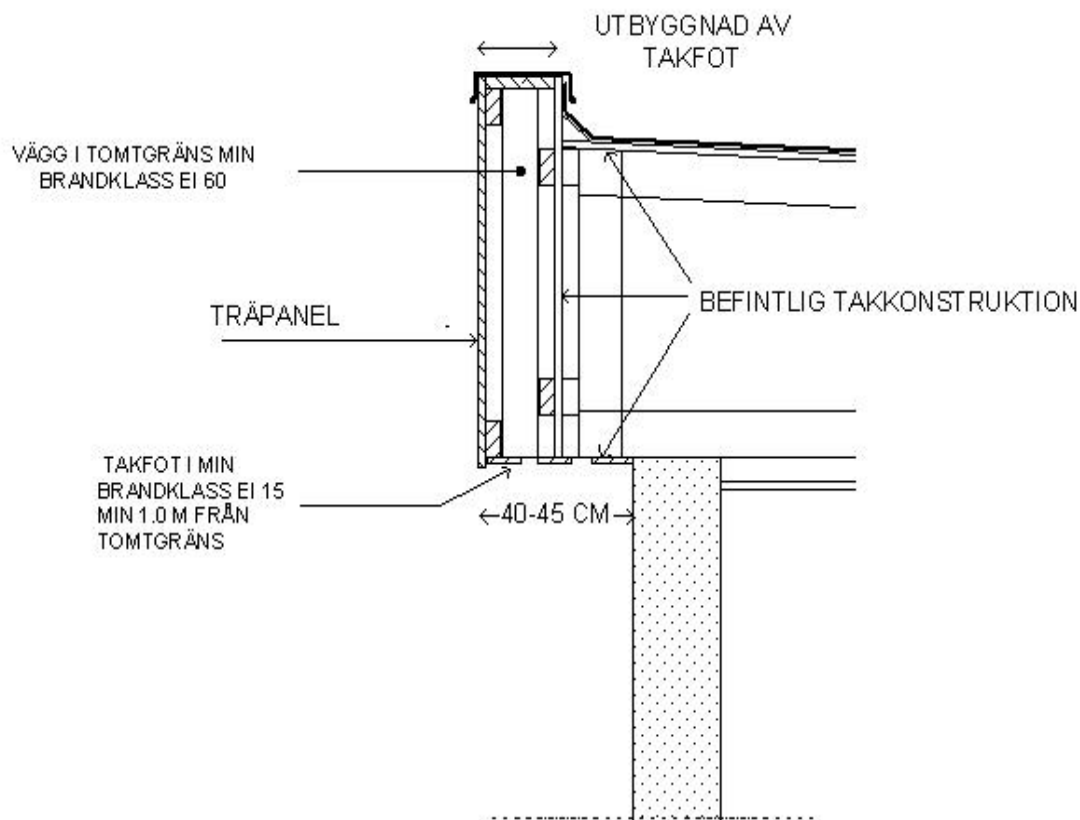

REV 2006 08 21

SALEMS KOMMUN

UTBYGGNAD TAKFOT, KEDJEHUS

FASTIGHET
ADRESS

SKALA 1.20

DATUM

K-2

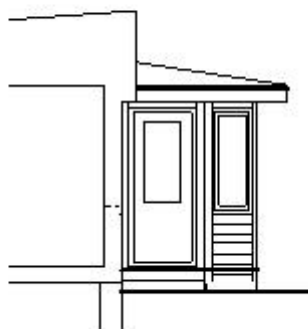
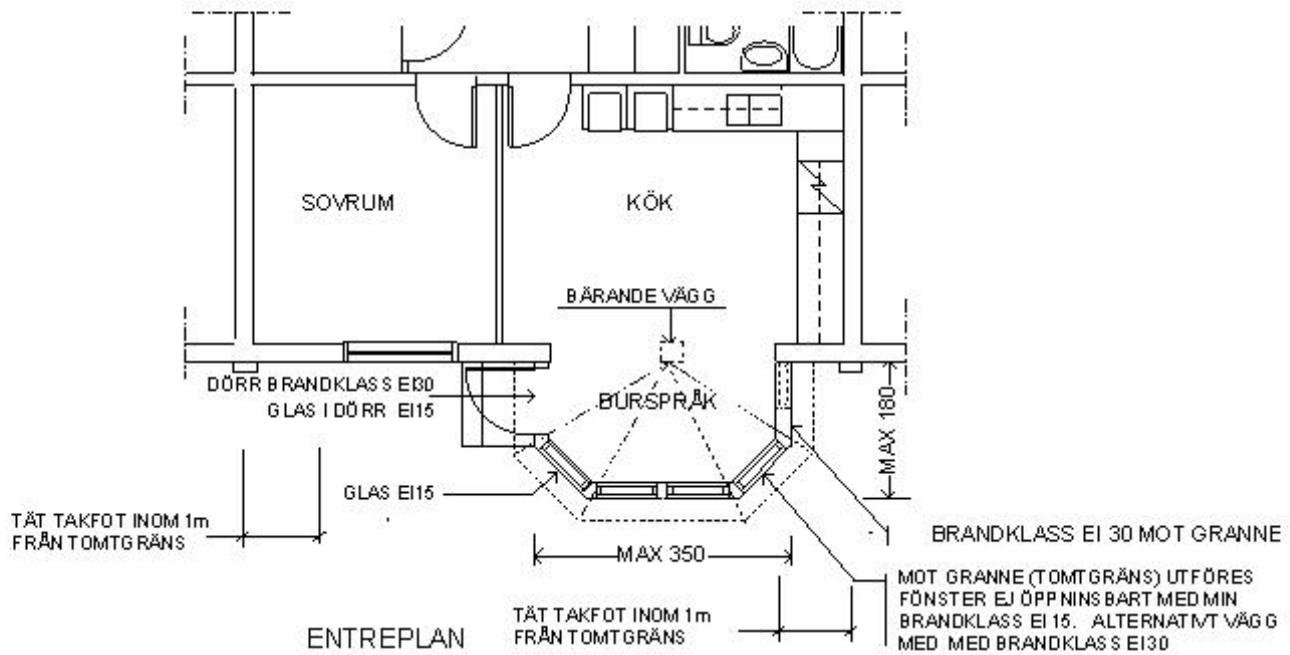

SIDOFASADER

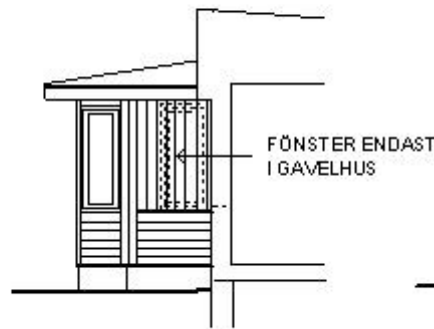

SEKTION

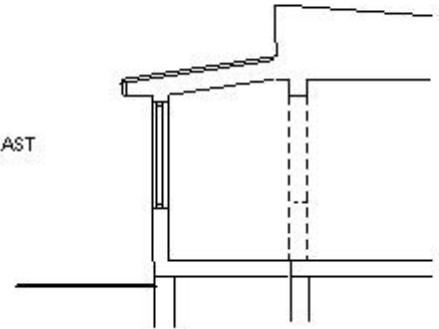

FASAD BURSPRÄK

REV 2008 05 16

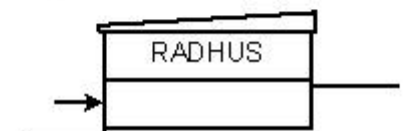

SALEMS KOMMUN

HUSTYP Dr

BURSPRÄK

FASTIGHET:

PLAN, FASADER

ADRESS:

SKALA 1:100

DATUM:

Dr-3

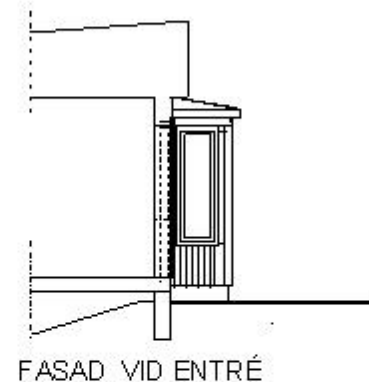
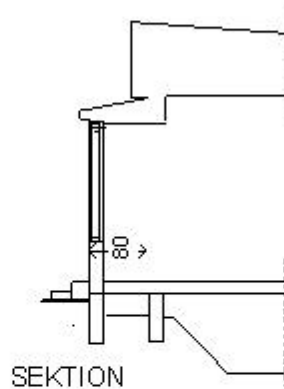
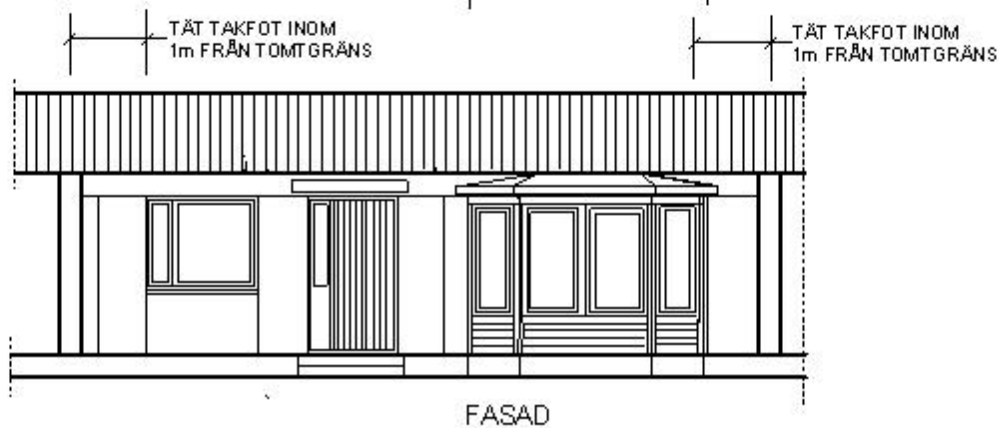
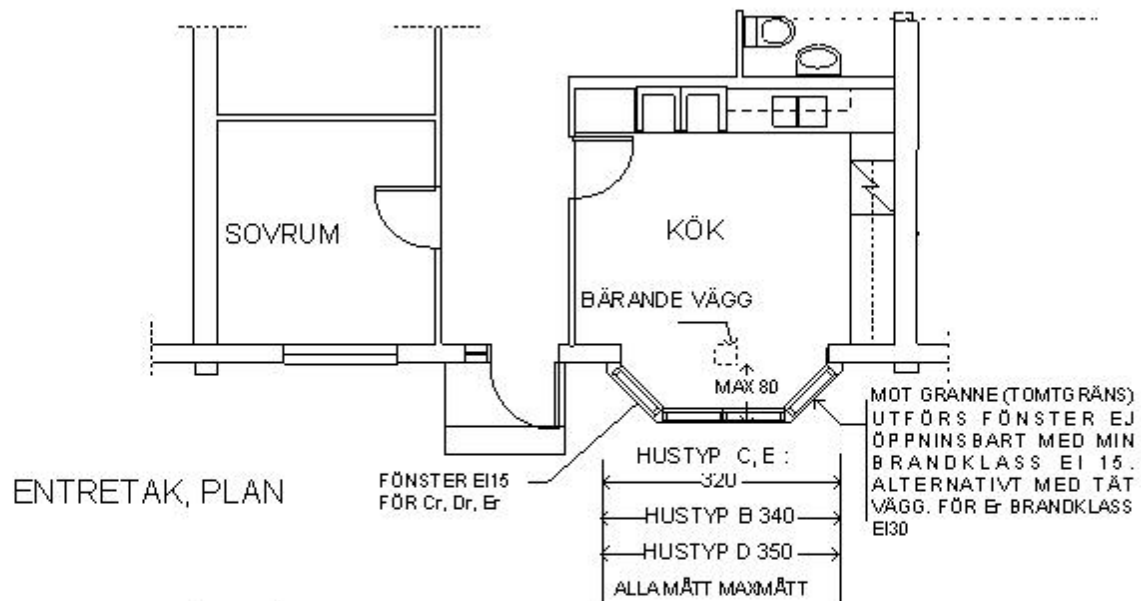

REV 2008 05 16

SALEMS KOMMUN

HUSTYP Br, Cr, Dr, Er

BURSPRÅK

FASTIGHET:

PLAN, FASADER

ADRESS:

SKALA 1:100

DATUM:

K-3

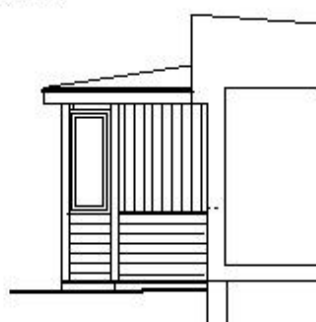
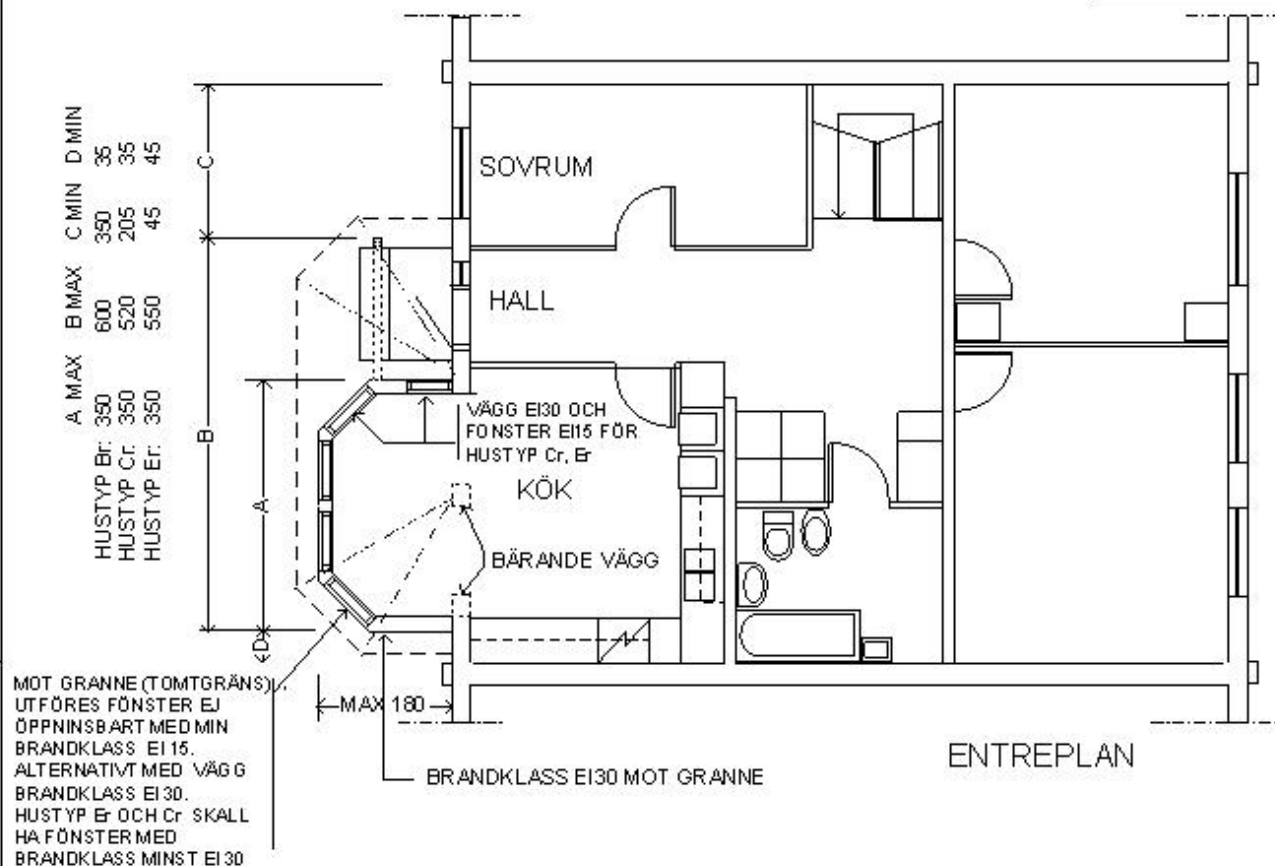

SIDOFASAD BURSPRÄK

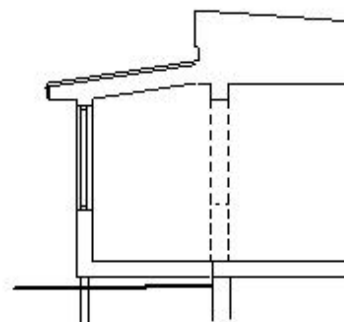

SEKTION BURSPRÄK

TÄT TAKFOT INOM 1m FRÅN TOMTGRÄNS

TÄT TAKFOT INOM 1m FRÅN TOMTGRÄNS

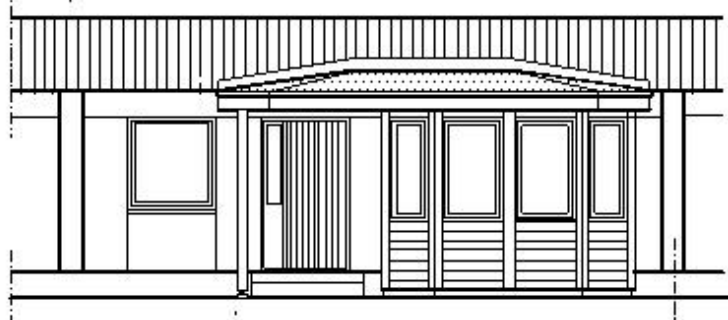

FASAD BURSPRÄK

REV 2008 05 16

SALEMS KOMMUN

HUSTYP Br, Cr, Er BURSPRÄK MED ENTRÉTAK

FASTIGHET:

PLAN, FASADER

ADRESS:

SKALA 1:100

DATUM:

K-4

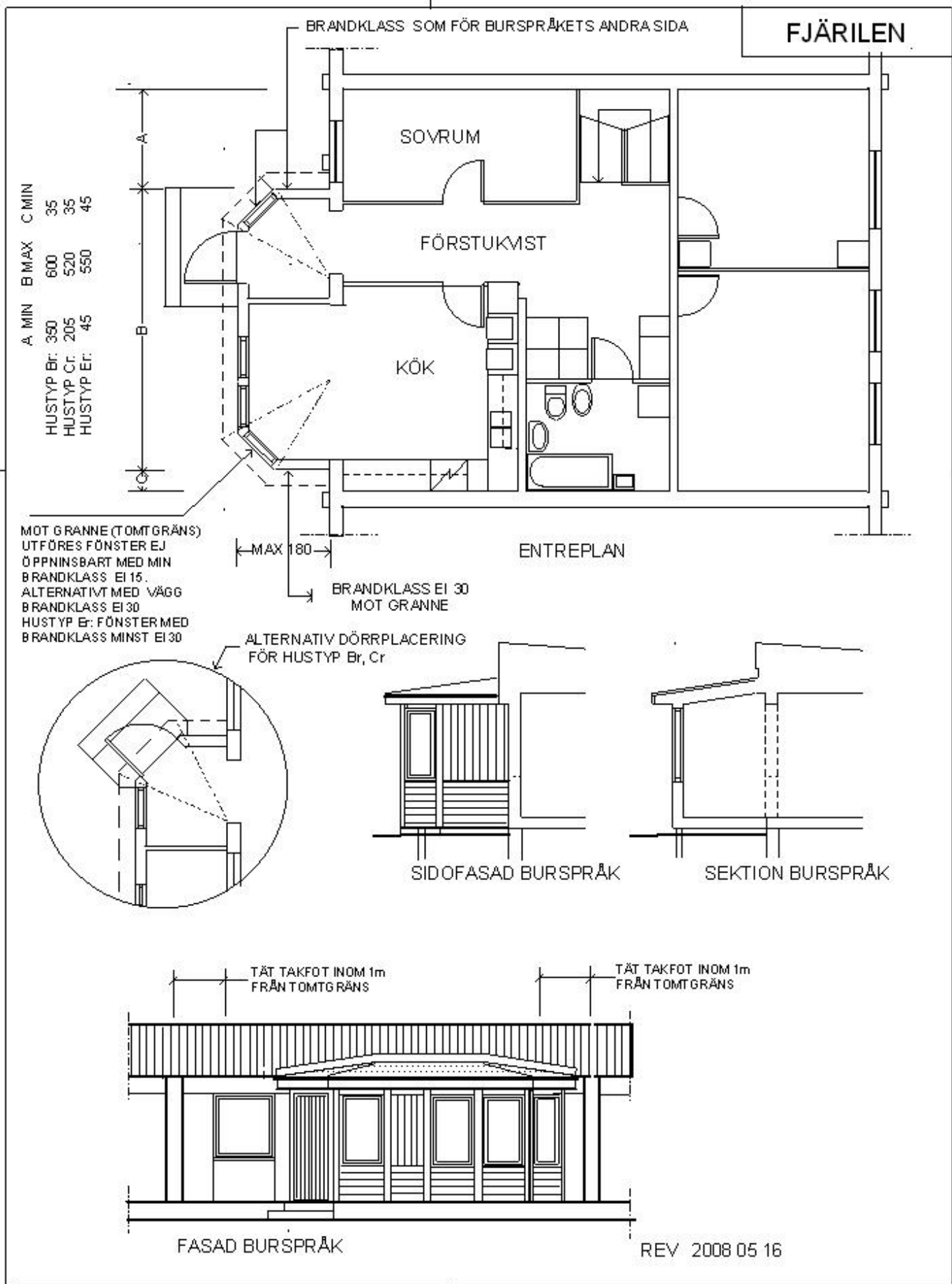

SALEMS KOMMUN	TYP: Br, Cr, Er BURSPRÄK MED INB FÖRSTUKMIST	
FASTIGHET: ADRESS:	PLAN, FASADER SKALA 1:100 DATUM:	K-5

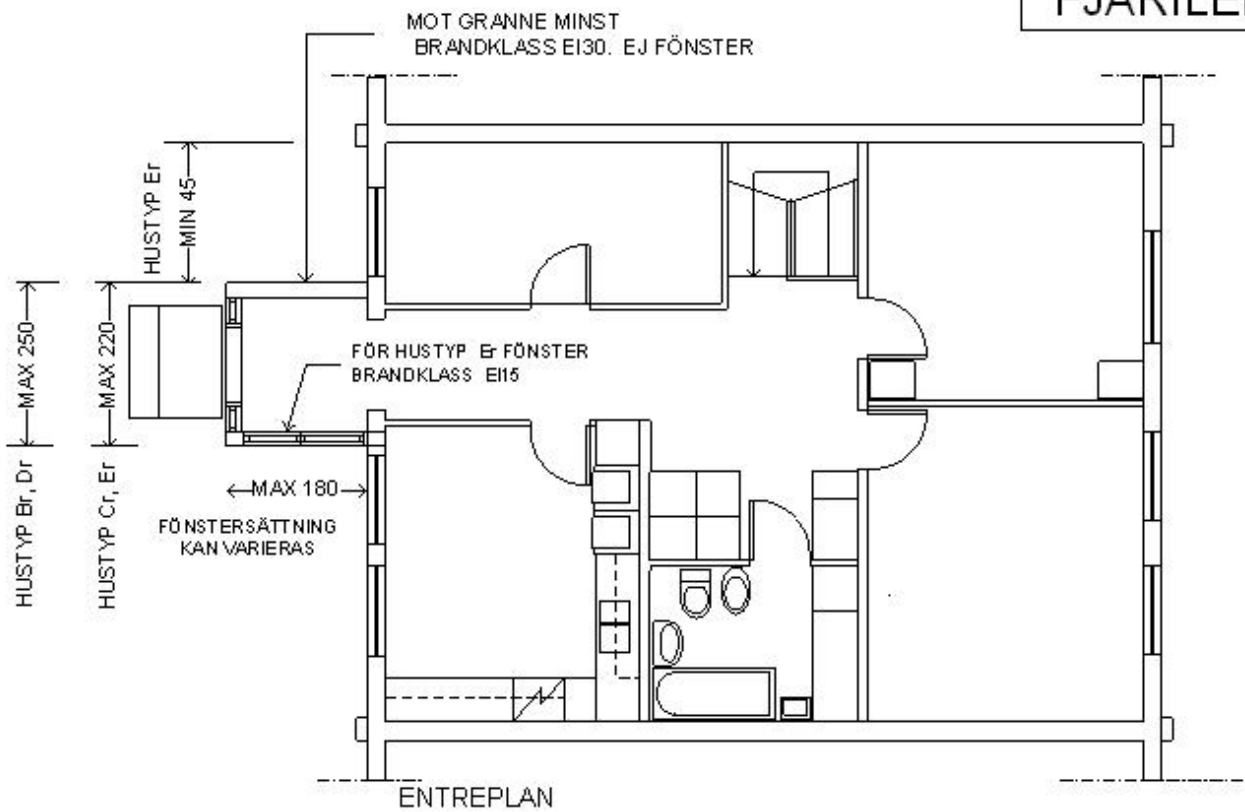

FASAD FÖRSTUKVIST TYP 1

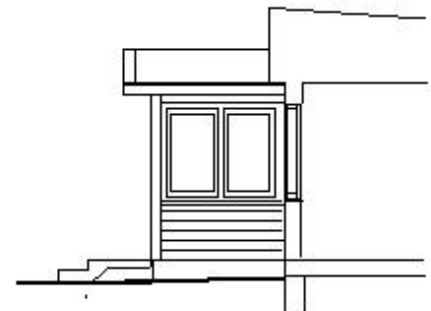

FASAD FÖRSTUKVIST TYP 1

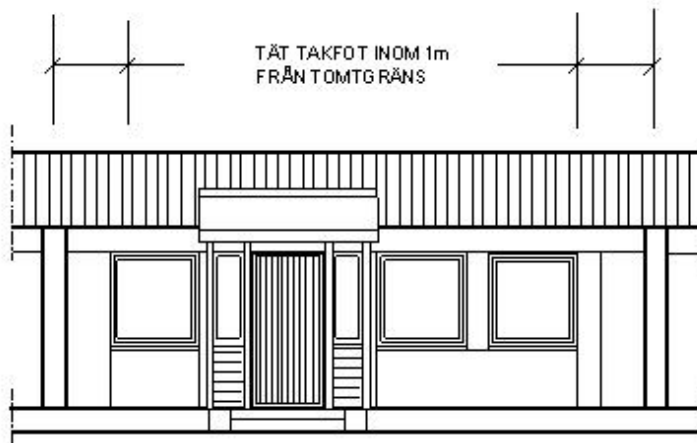

FASAD FÖRSTUKVIST TYP 2

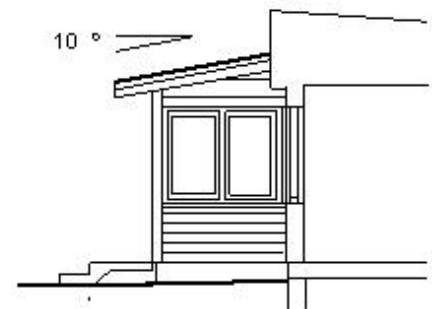

FASAD FÖRSTUKVIST TYP 2

REV 2008 05 16

SALEMS KOMMUN

HUSTYP Br, CR, Dr, Er

FÖRSTUKVIST

FASTIGHET:

PLAN, FASADER

ADRESS:

SKALA 1:100

DATUM:

K-6

FJÄRILEN

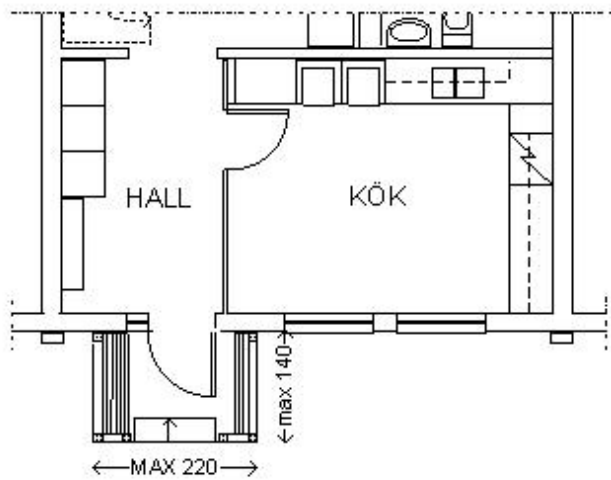

PLAN

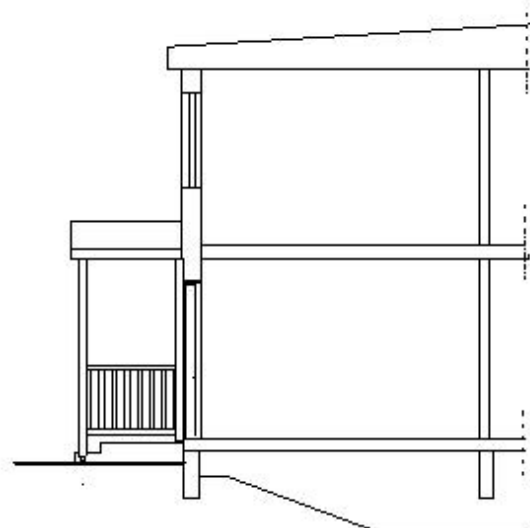

FASAD ALT 1



FASAD ALT 1

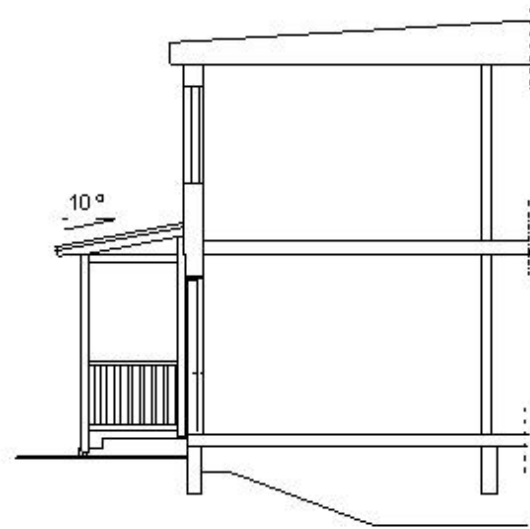

SEKTION ALT 2



FASAD ALT 2

2008 03 17

SALEMS KOMMUN

HUSTYP Br, Cr, Dr, Er

ENTRÉTAK

FASTIGHET:

PLAN, FASADER

ADRESS:

SKALA 1:100

DATUM:

K-7

FJÄRILEN

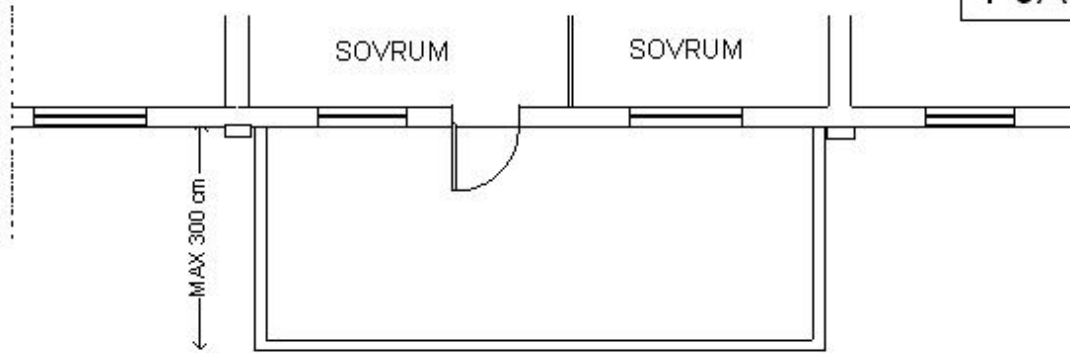

BALKONG, ÖVRE PLAN

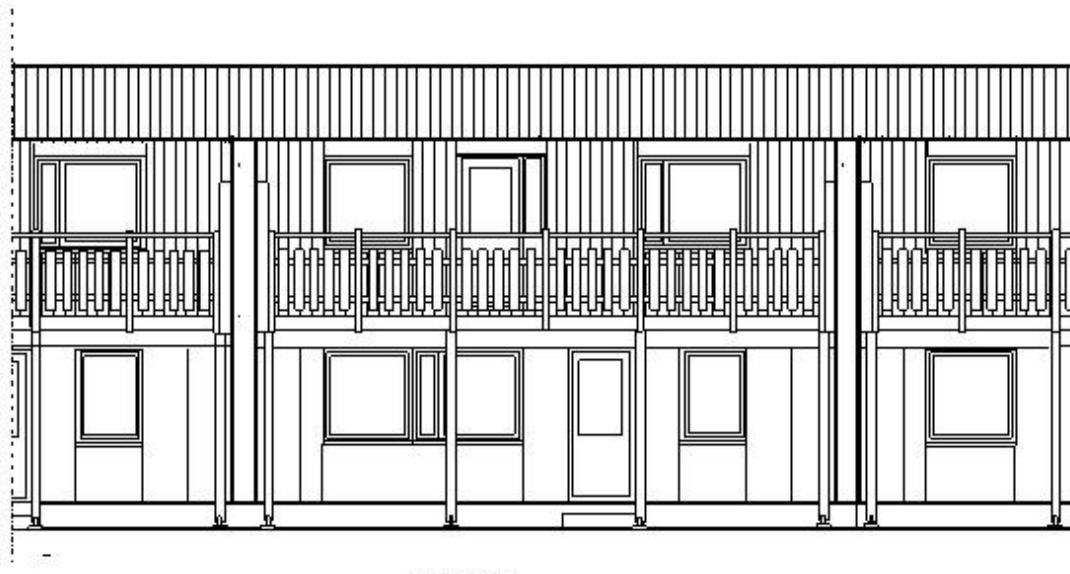

FASAD

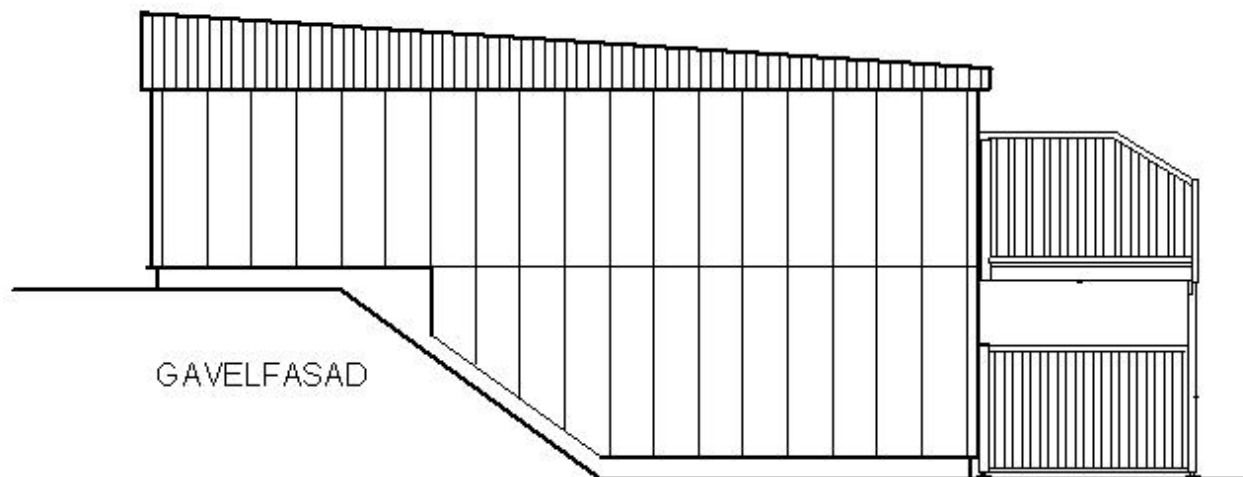

GAVELFASAD

2008 03 17

SALEMS KOMMUN

HUSTYP Cr, Dr

BALKONG

FASTIGHET:

PLAN, FASADER

ADRESS:

SKALA 1:100

DATUM:

K-8

FJÄRILEN

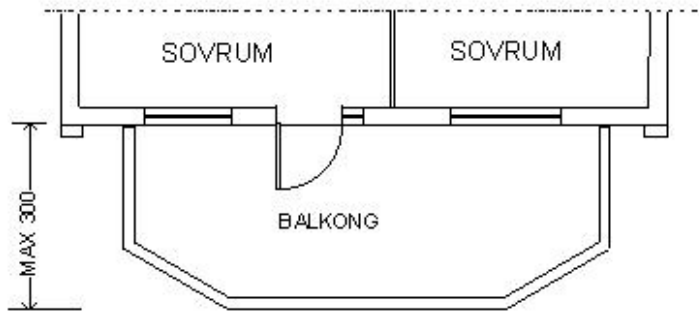

BALKONG, ÖVRE PLAN

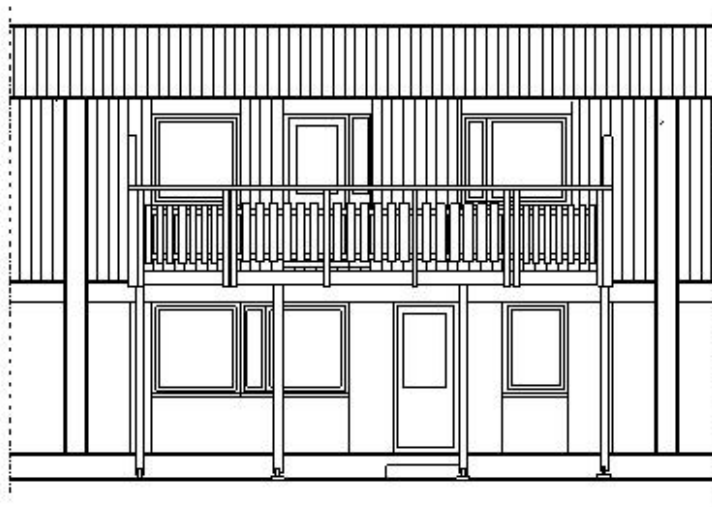

FASAD

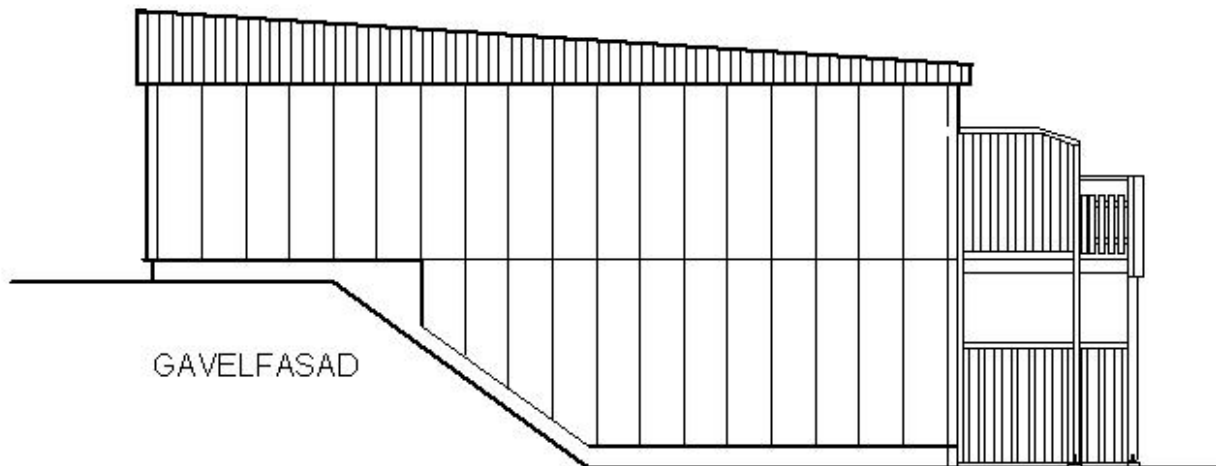

GAVELFASAD

REV 2008 05 16

SALEMS KOMMUN

HUSTYP Cr, Dr

BALKONG

FASTIGHET:

PLAN, FASADER

ADRESS:

SKALA 1: 100

DATUM:

K-9

FJÄRILEN

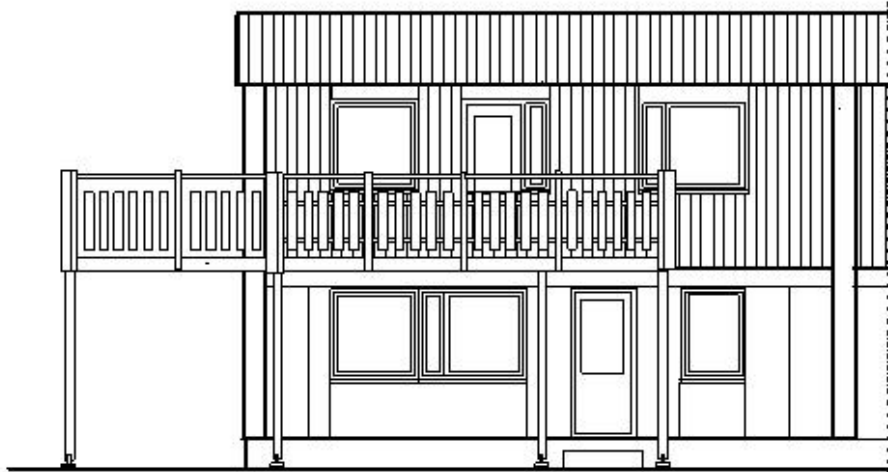

FASAD

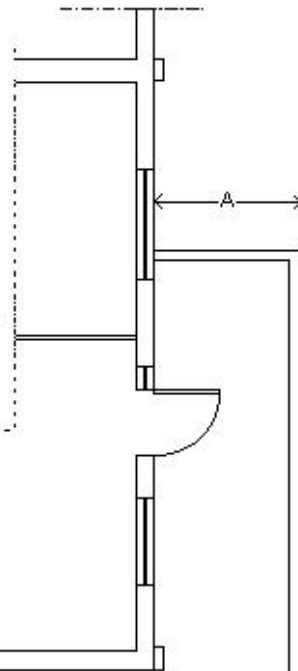

BALKONG

MAX 580

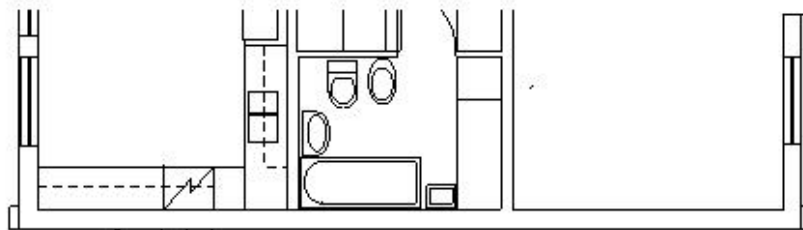

ENTRÉPLAN

A MAX 200 OCH B MAX 300
 ELLER A MAX 300 OCH B MAX 200
 MÄTTSÄTTNINGEN (SPEGELVÄND) GÄLLER
 ÄVEN HUSETS ANDRA GAVEL

MAX 1000

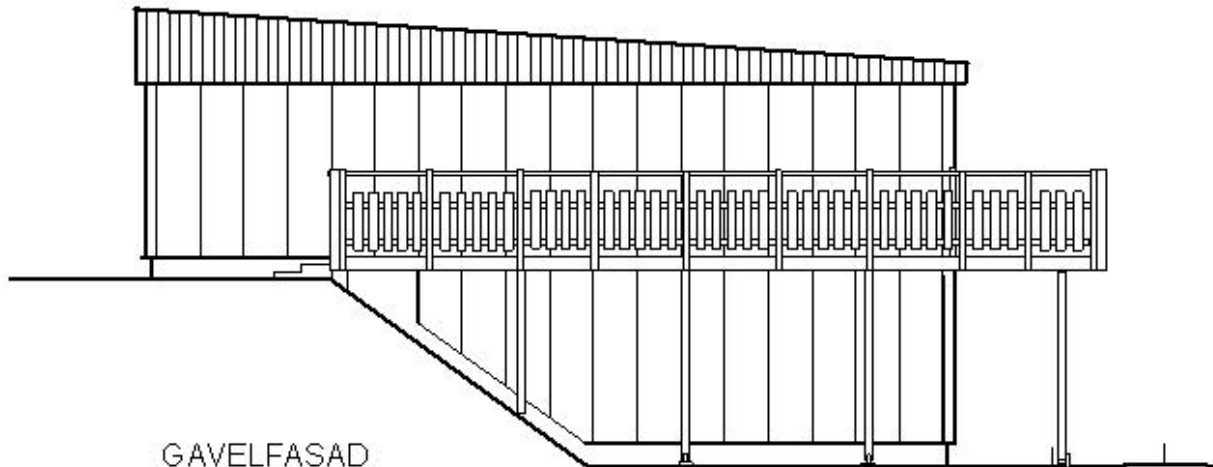

GAVELFASAD

REV 2008 03 17

SALEMS KOMMUN

HUSTYP CR, Dr

BALKONG GAVEL

FASTIGHET:

PLAN, FASADER

ADRESS:

SKALA 1:100

DATUM:

K-10