

FASAD

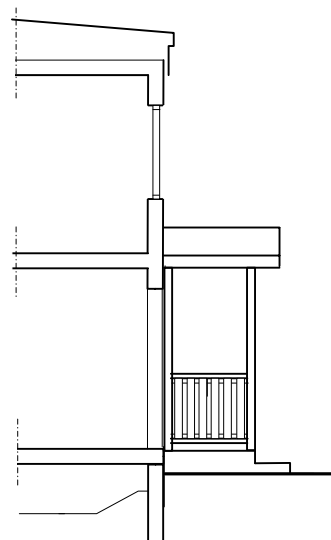

SEKTION/FASAD



FASAD

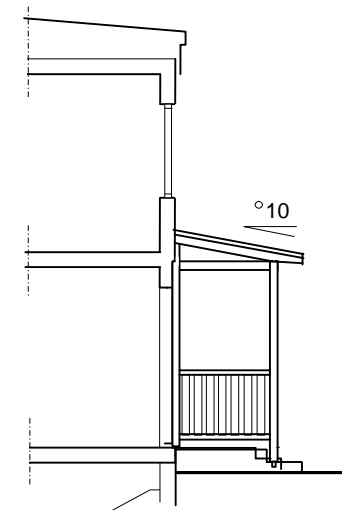

RITNGEN GÄLLER
I PRINCIP S1, S2
OCH S3

SKISS 20110418

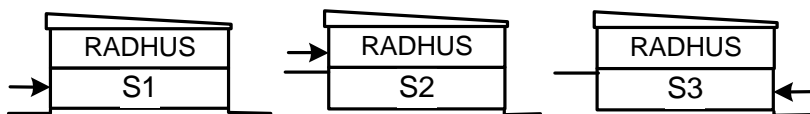

SALEMS KOMMUN

HUSTYP S1, S2 OCH S3

ENTRETAK, SADEL/
PULPET

FASTIGHET:
ADRESS:

PLAN, FASADER
SKALA 1:100

DATUM:

K3

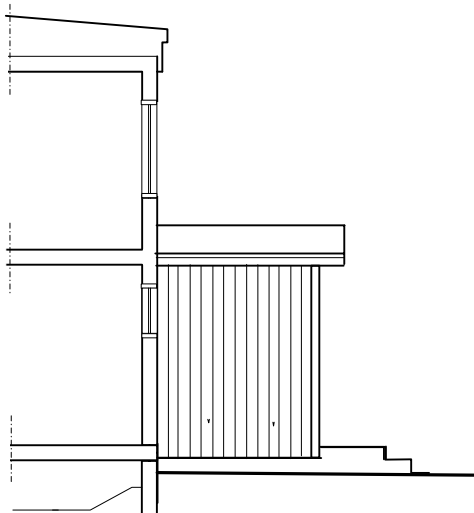
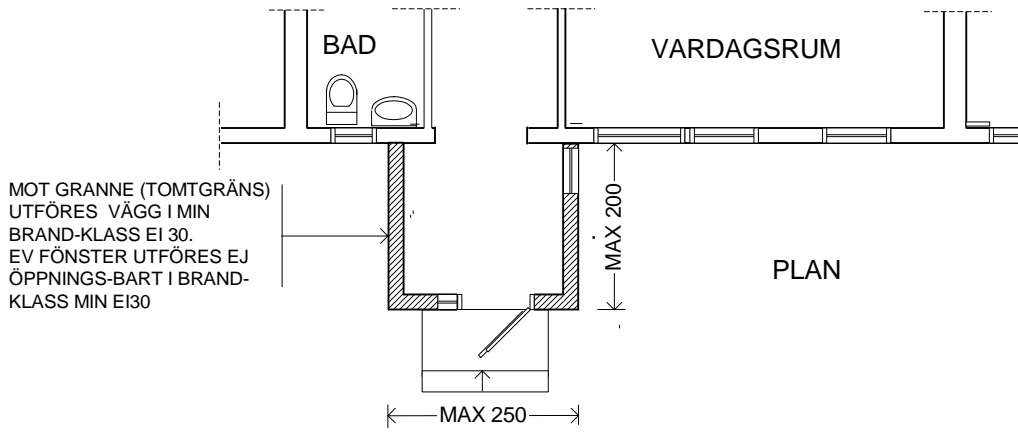

SEKTION/FASAD

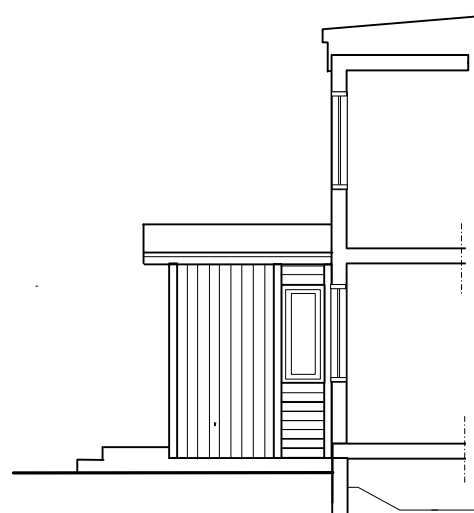

SEKTION/FASAD

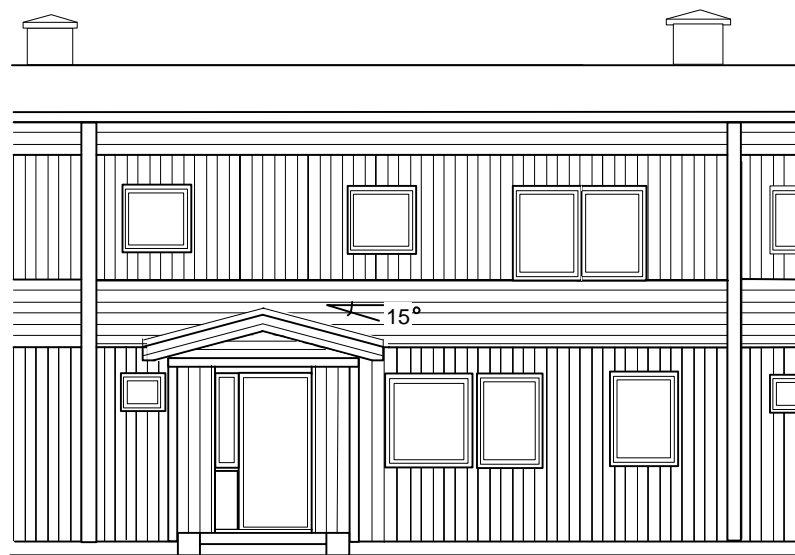

FASAD

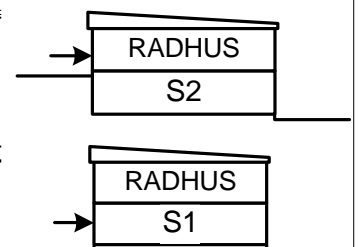

SKISS 20110418

SALEMS KOMMUN

HUSTYP S1, S2

FÖRSTUKVIST MED SADELTAK

FASTIGHET:

PLAN, FASADER

ADRESS:

SKALA 1:100

DATUM:

K4

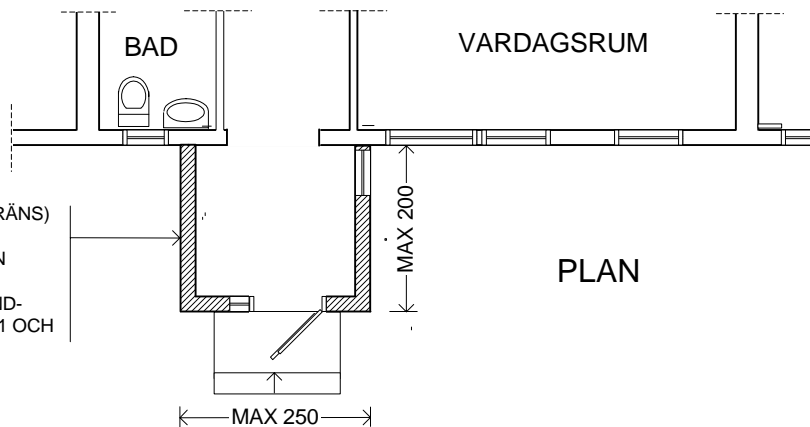

MOT GRANNE (TOMTGRÄNS)
 UTFÖRES FÖNSTER EJ
 ÖPPNINGSBART MED MIN
 BRANDKLASS EI 15.
 VÄGG UTFÖRES I BRAND-
 KLASS EI 30. GÄLLER S1 OCH
 S2

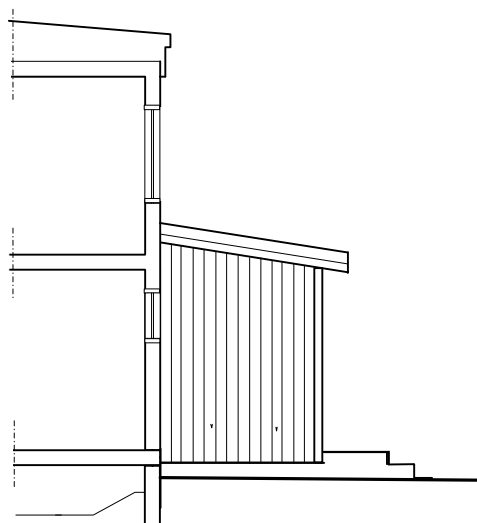

SEKTION/FASAD

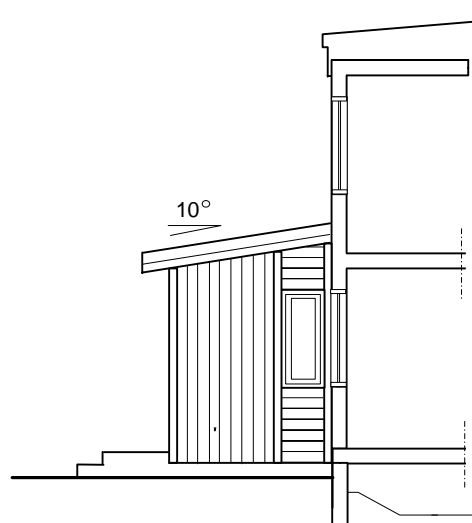

SEKTION/FASAD



FASAD

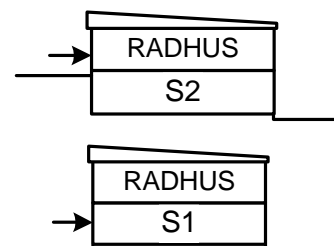

SKISS 20110418

SALEMS KOMMUN

HUSTYP S1, S2

FÖRSTUKVIST PULPETTAK

FASTIGHET:

PLAN, FASADER

ADRESS:

SKALA 1:100

DATUM:

K5

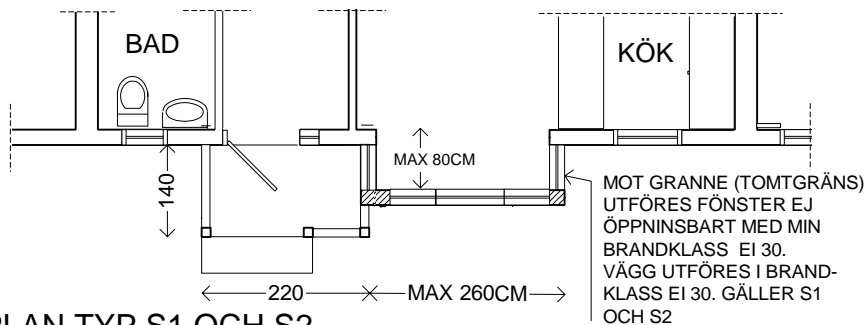

PLAN TYP S1 OCH S2
SAMT I PRINCIP S3



FASAD TYP S3

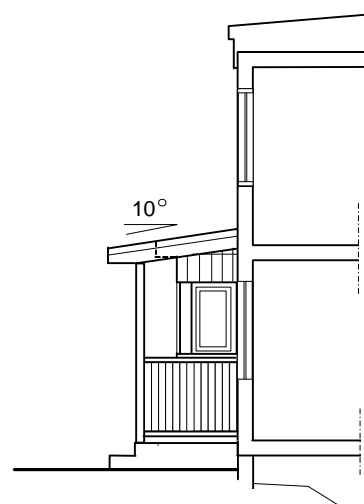

SEKTION/FASAD



FASAD TYP S1 SAMT I PRINCIP S2

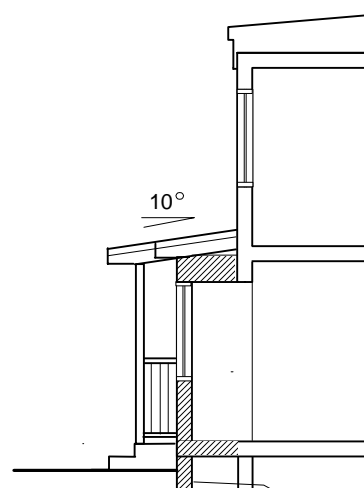

SEKTION/FASAD

SKISS 20110418

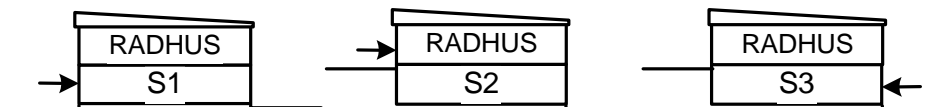

SALEMS KOMMUN

HUSTYP S1, S2, S3

ENTRETAK OCH BURSFRÅK MED
PULPETTAK

FASTIGHET:

PLAN, FASADER

ADRESS:

SKALA 1:100

DATUM:

K6

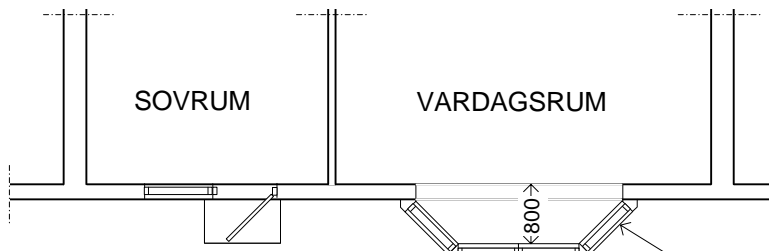

GÄLLER S1

← MAX 320 →

PLAN

MOT GRANNE (TOMTGRÄNS)
 UTFÖRS FÖNSTER EJ
 ÖPPNINGSBART MED MIN
 BRANDKLASS EI 15.
 ALTERNATIVT MED TÄT VÄGG
 MED BRANDKLASS MINST EI30

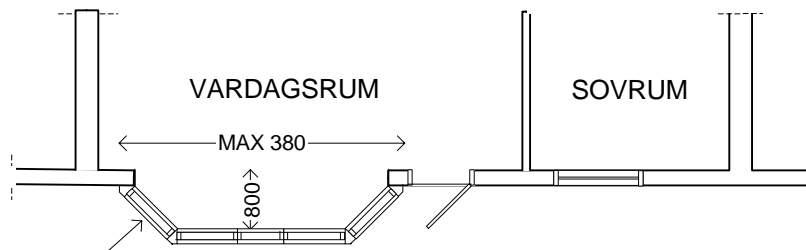

GÄLLER S2 OCH S3

MOT GRANNE (TOMTGRÄNS)
 UTFÖRS FÖNSTER EJ
 ÖPPNINGSBART MED MIN
 BRANDKLASS EI 15.
 ALTERNATIVT MED TÄT
 VÄGG MED BRANDKLASS
 MINST EI30

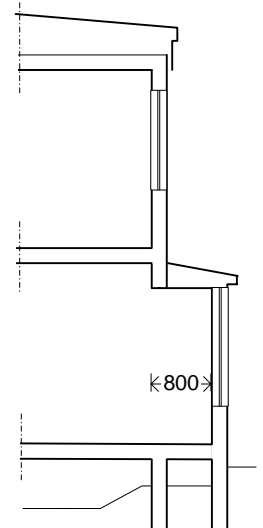

SEKTION



FASAD S1

GÄLLER I PRINCIP
 ÄVEN S2 OCH S3

SKISS 20110418

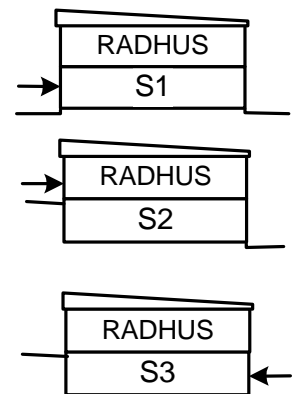

SALEMS KOMMUN

HUSTYP S1, S2, S3 BURSPRÅK PÅ BAKSIDAN

FASTIGHET:

PLAN, FASADER

ADRESS:

SKALA 1:100

DATUM:

K7

FASANEN

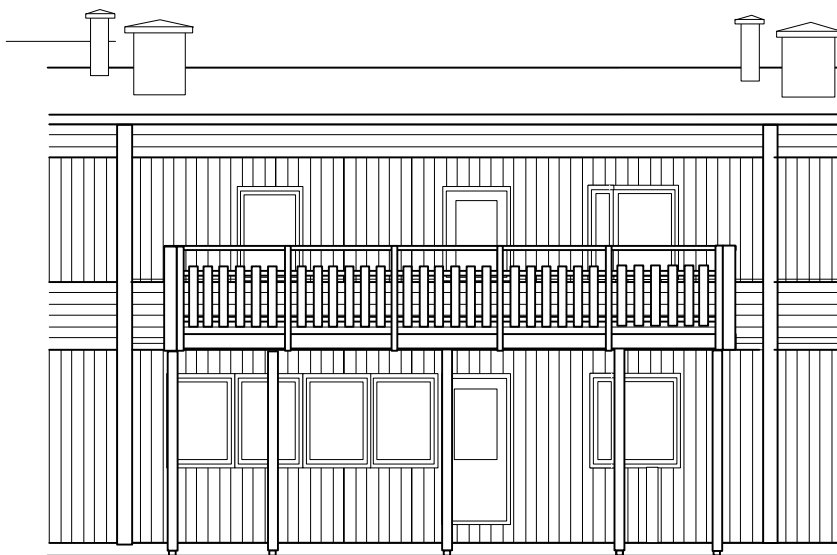
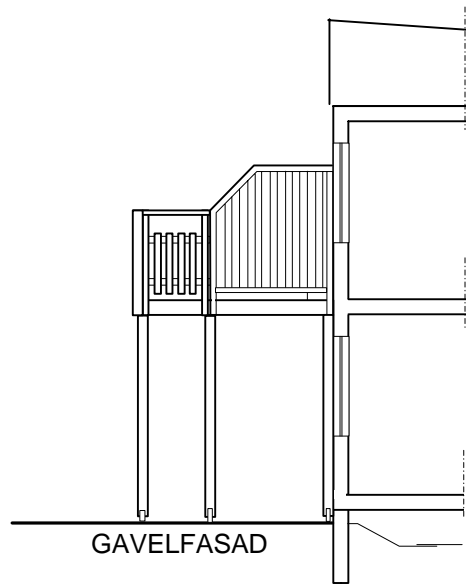
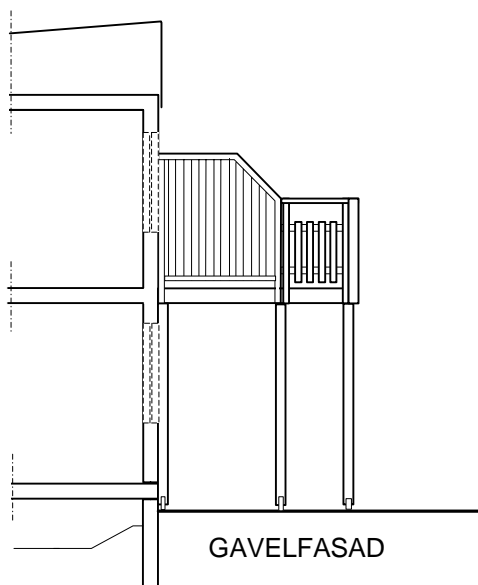
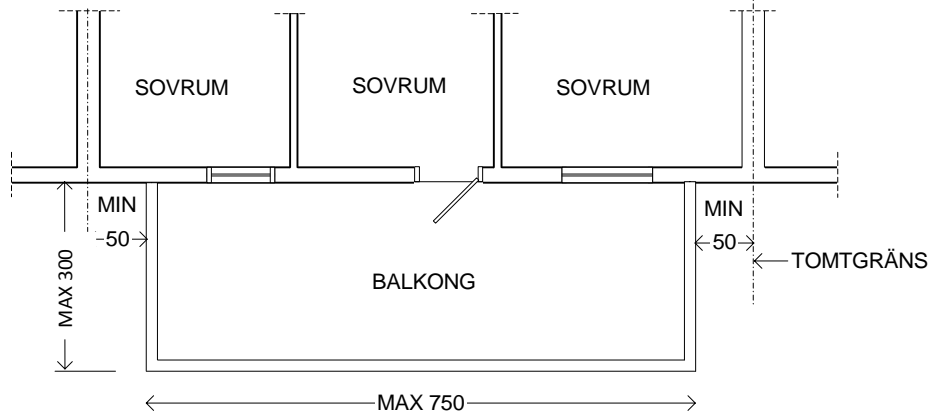

BALKONGRITNINGEN
GÄLLER I PRINCIP ALLA
TVÅVÅNINGSS FASADER FÖR
HUSTYP S1,S2 OCH S3

FASAD

SKISS 20110418

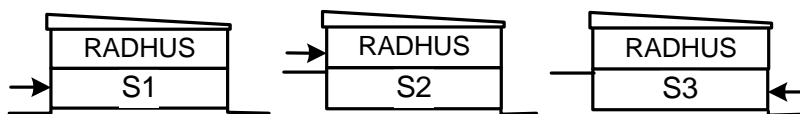

SALEMS KOMMUN

HUSTYP S1, S2, S3 BALKONG, RAKA HÖRN

FASTIGHET:

PLAN, FASADER

ADRESS:

SKALA 1:100

DATUM:

K8

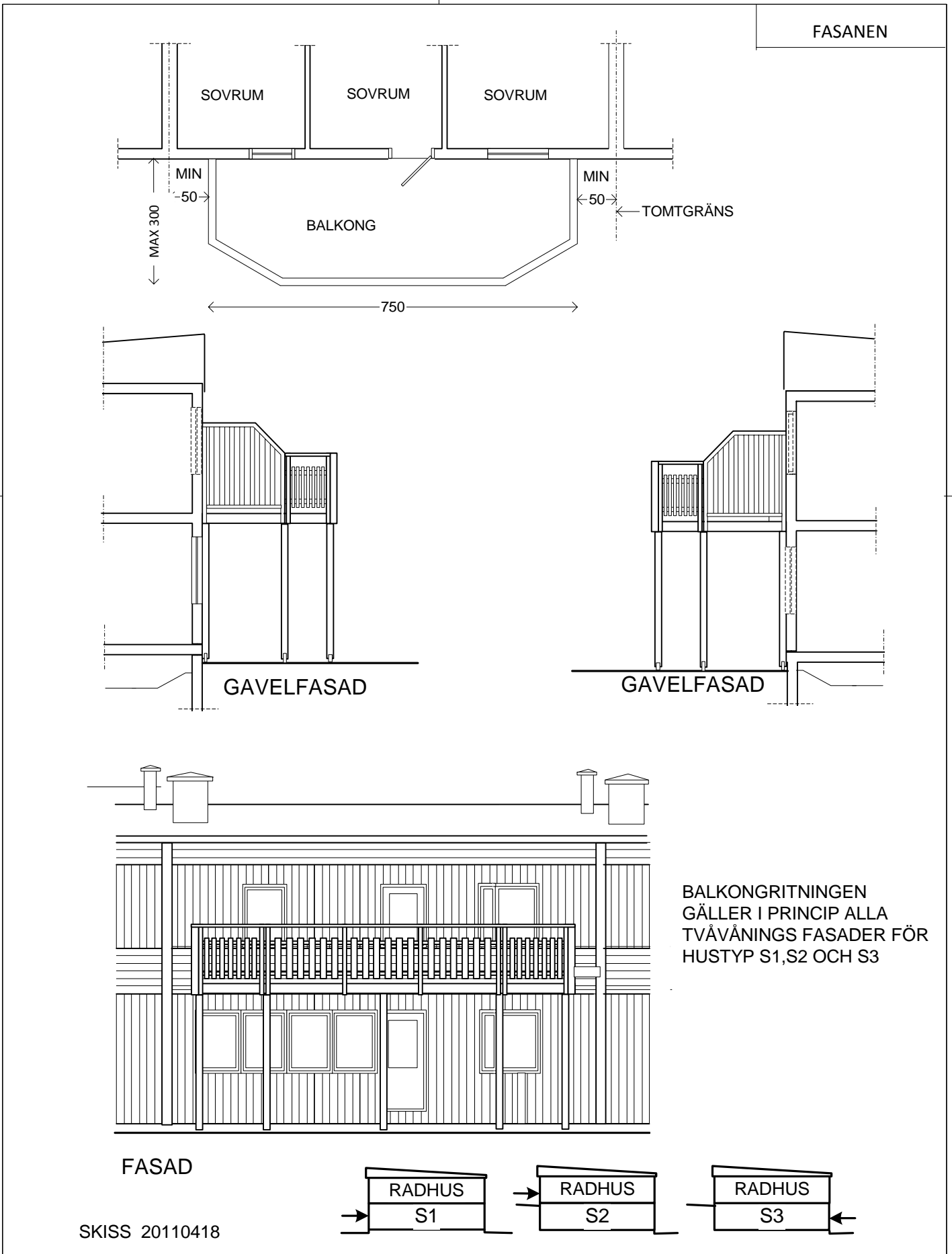

FASANEN

SOVRUM

SOVRUM

SOVRUM

MIN
50

MIN
50

TOMTGRÄNS

BALKONG

MAX 300

750

GAVELFASAD

GAVELFASAD

FASAD

BALKONGRITNINGEN
GÄLLER I PRINCIP ALLA
TVÅVÅNINGS FASADER FÖR
HUSTYP S1,S2 OCH S3

SKISS 20110418

RADHUS
S1

RADHUS
S2

RADHUS
S3

SALEMS KOMMUN

HUSTYP S1, S2, S3 BALKONG, FASADE HÖRN

FASTIGHET:

PLAN, FASADER

ADRESS:

SKALA 1:100

DATUM:

K9

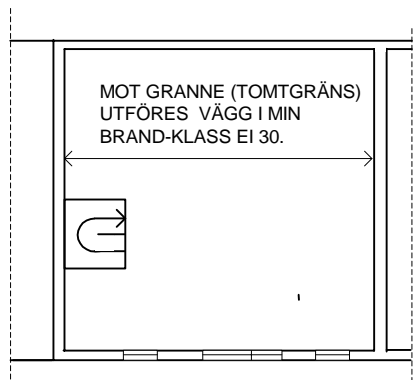

PÅBYGD VÅNINGSPÅN
SKALA 1:200

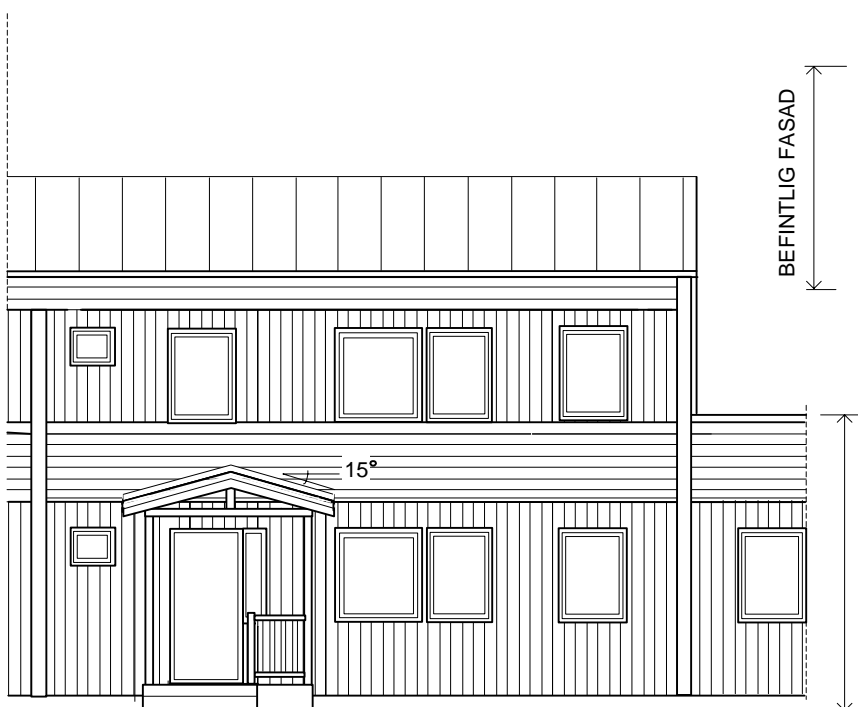
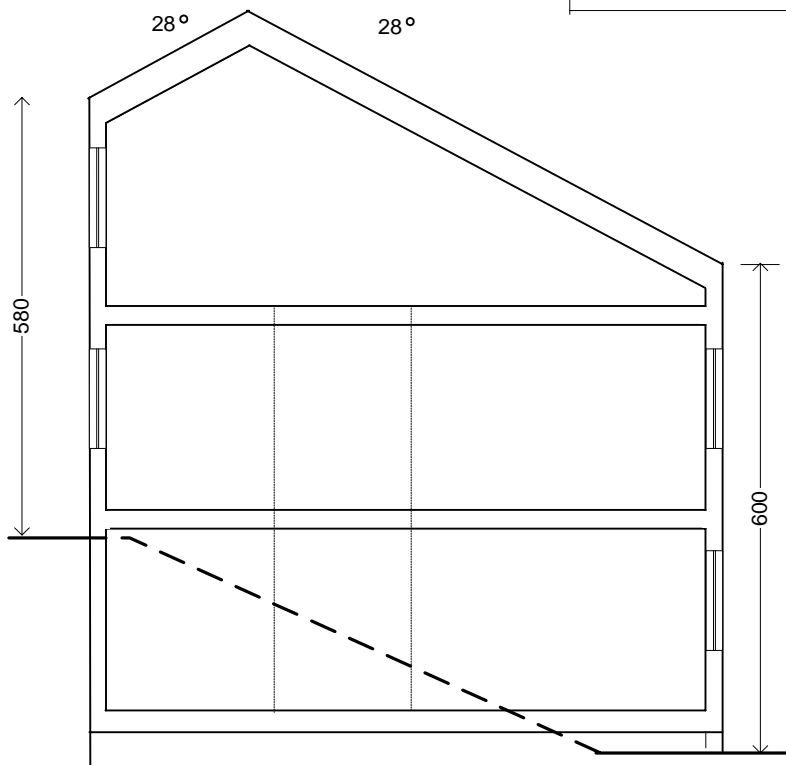

NY FASAD SKALA 1:100

SKISS 20110418

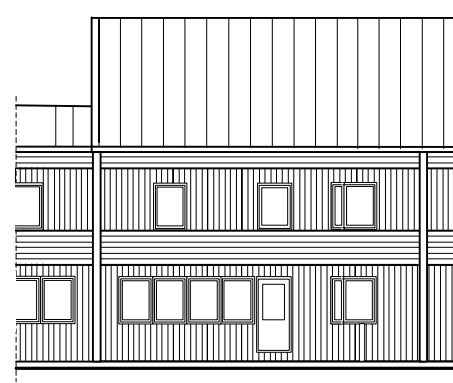

SKALA 1:200

SKISSRITNINGEN VISAR
TYP S2 MEN GÄLLER I
PRINCIP ÄVEN TYP S3

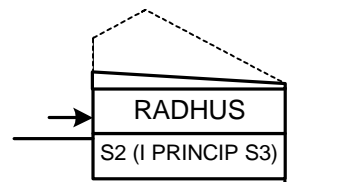

SALEMS KOMMUN

HUSTYP S2, PÅBYGGNAD VIND, SADELTAK.

FASTIGHET:

PLAN, FASADER

ADRESS:

SKALA 1:100

DATUM:

K10

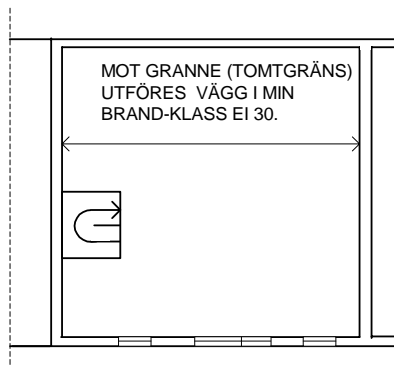

PÅBYGD VÅNINGSPÄN
SKALA 1:200

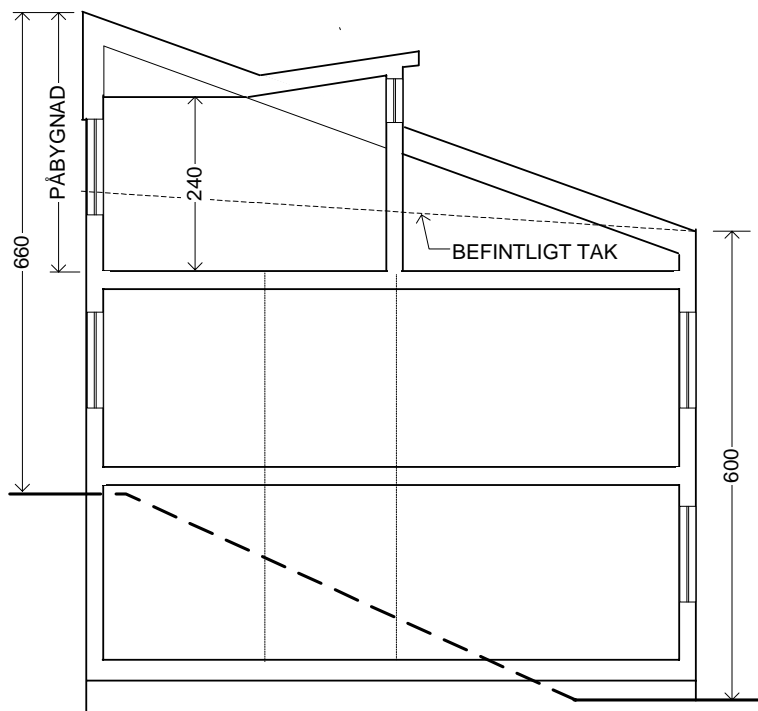

NY FASAD SKALA 1:100

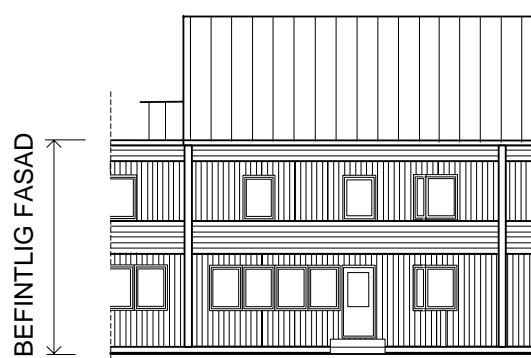

SKALA 1:200

RITNINGEN VISAR TYP
S2 MEN GÄLLER I
PRINCIP ÄVEN TYP S3

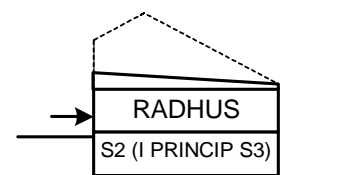

SKISS 20110418

SALEMS KOMMUN

HUSTYP S2, S3. PÅBYGGNAD VIND, PULPETTAK.

FASTIGHET:

PLAN, FASADER

ADRESS:

SKALA 1:100

DATUM:

K-11

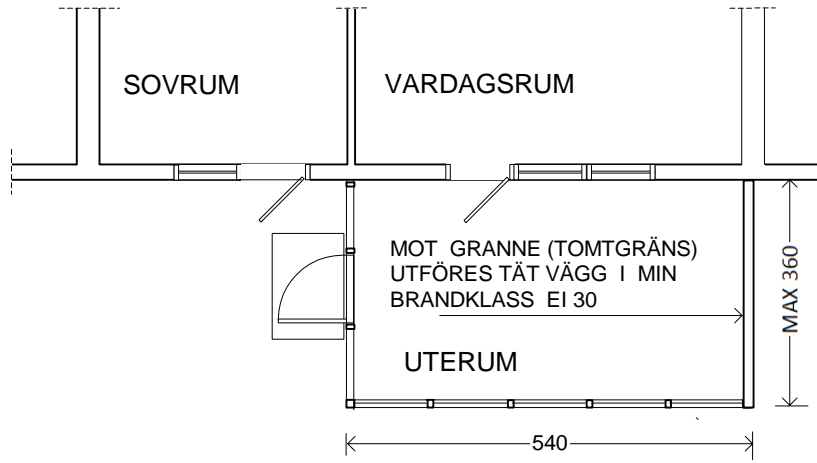

PLAN

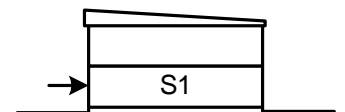
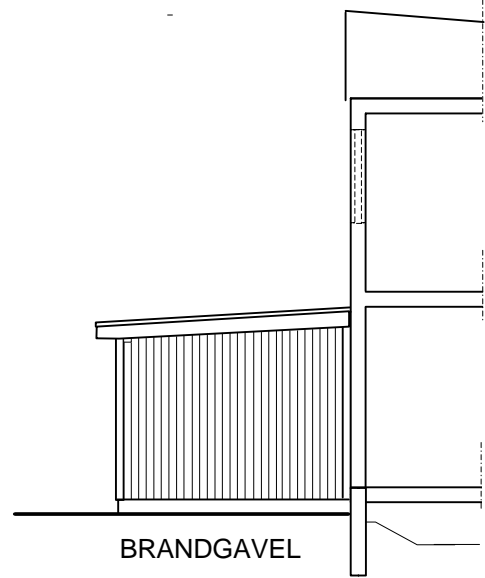
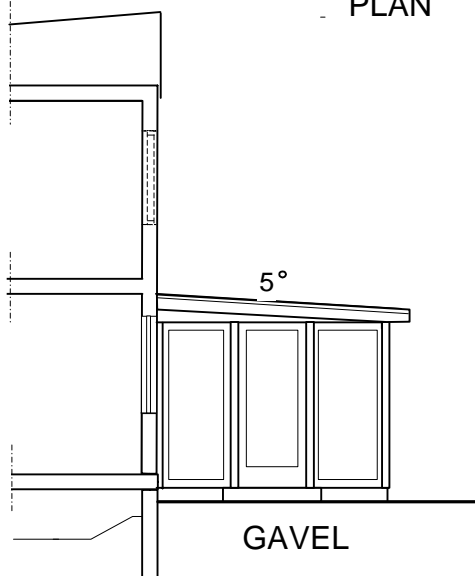

SKISS 20110418

SALEMS KOMMUN

HUSTYP S1 INGLASAT UTERUM VID VARDAGSRUM

FASTIGHET:

PLAN, FASADER

ADRESS:

SKALA 1:100

DATUM:

S1-1

FASANEN

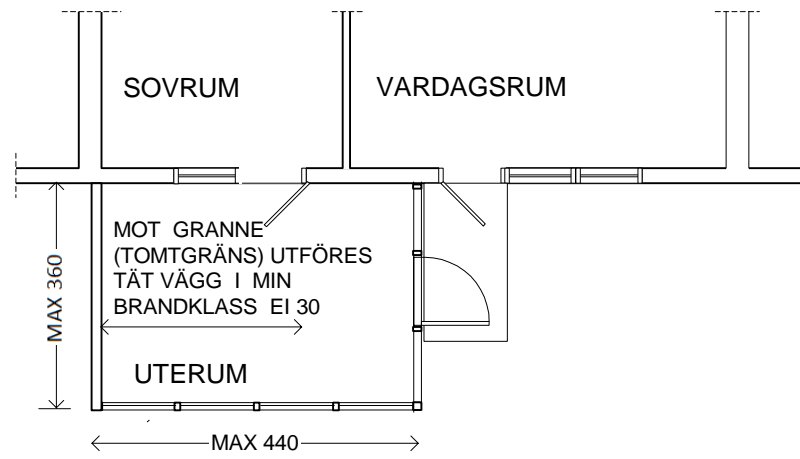

PLAN,

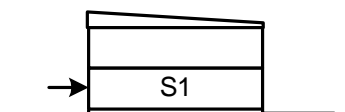
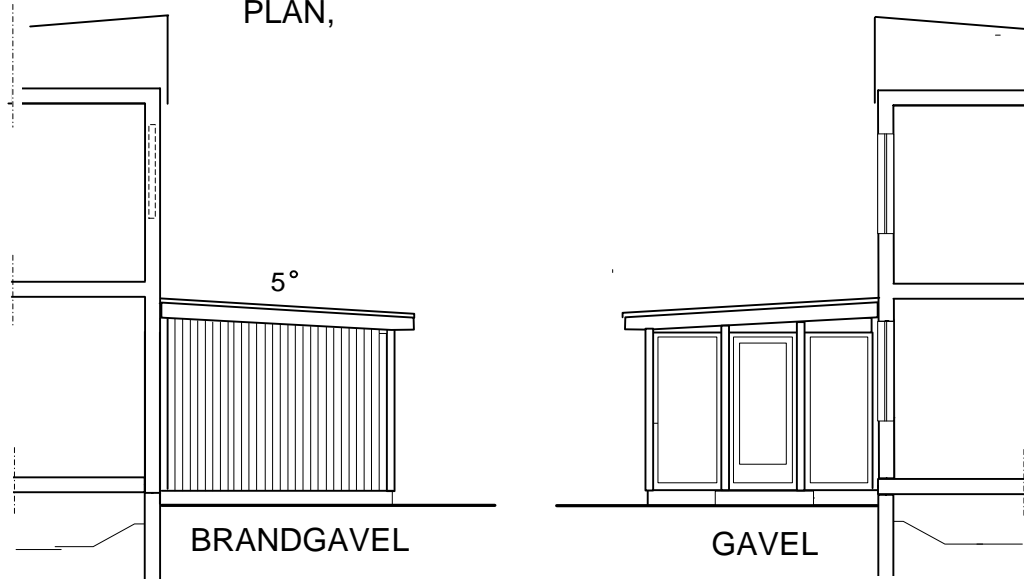

SKISS 20110418

SALEMS KOMMUN

HUSTYP S1

INGLASAT UTERUM VID SOVRUM

FASTIGHET:

PLAN, FASADER

ADRESS:

SKALA 1:100

DATUM:

S1-2

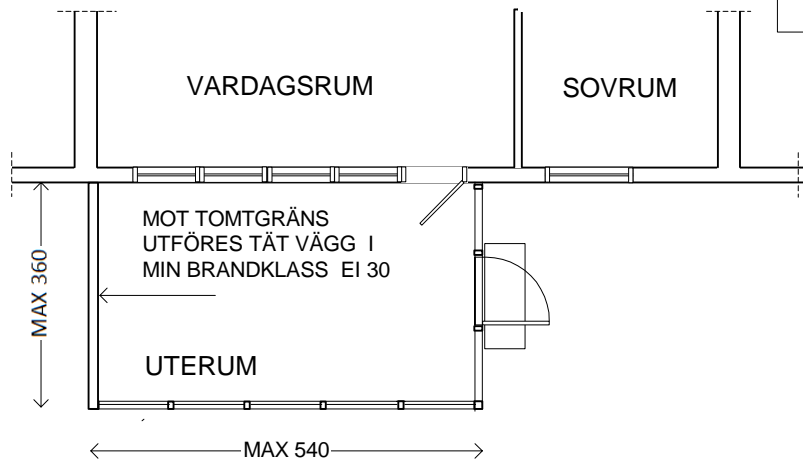

PLAN

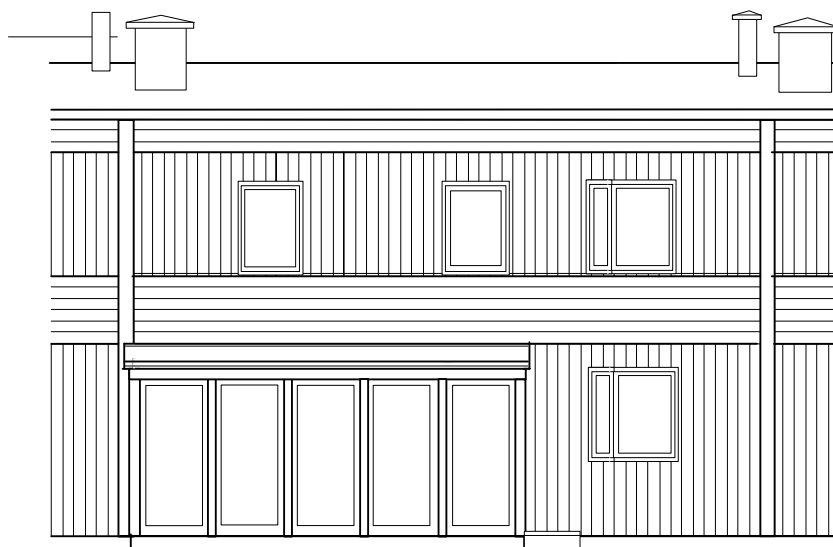
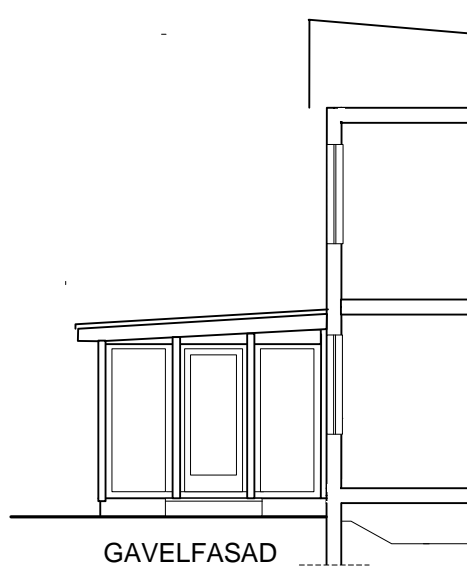
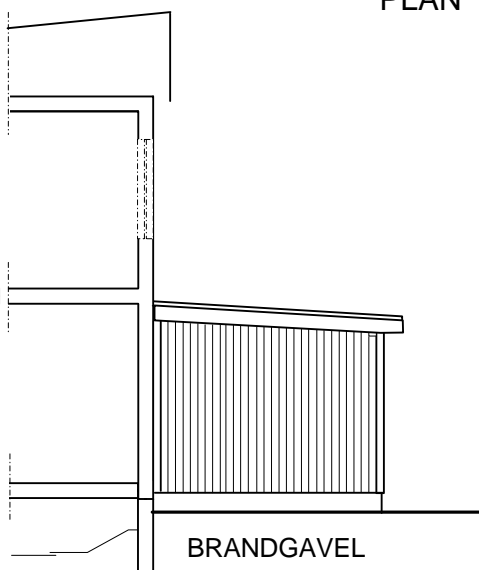

SKISS 2012015

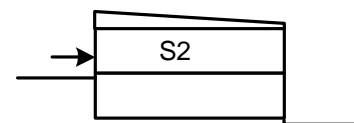

SALEMS KOMMUN

HUSTYP S2 INGLASAT UTERUM VID VARDAGSRUM

FASTIGHET:

PLAN, FASADER

ADRESS:

SKALA 1:100

DATUM:

S2-1

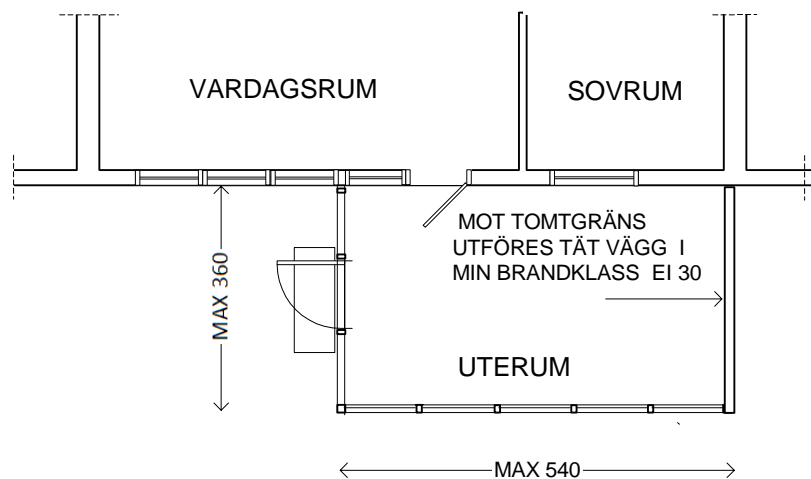

PLAN

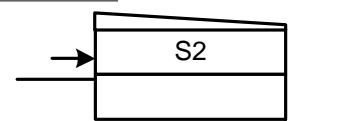
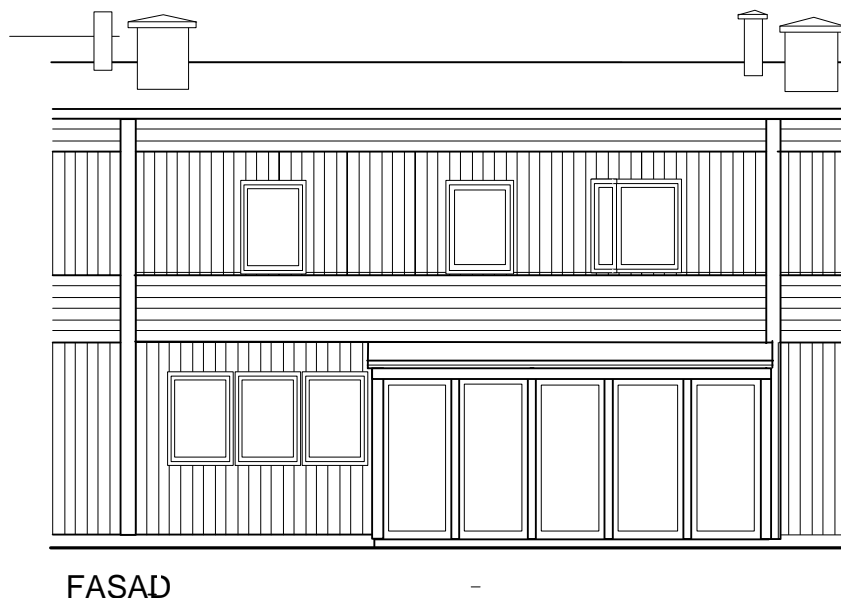
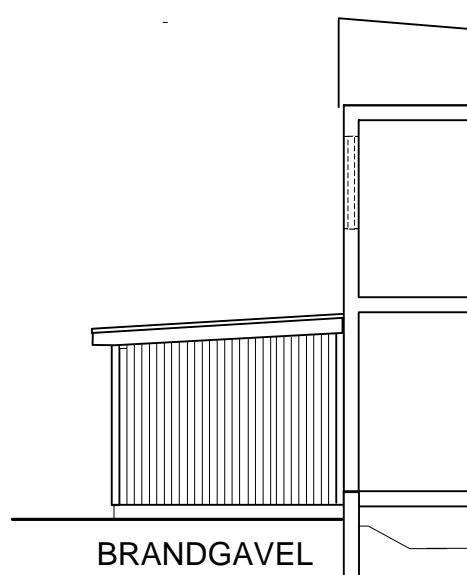
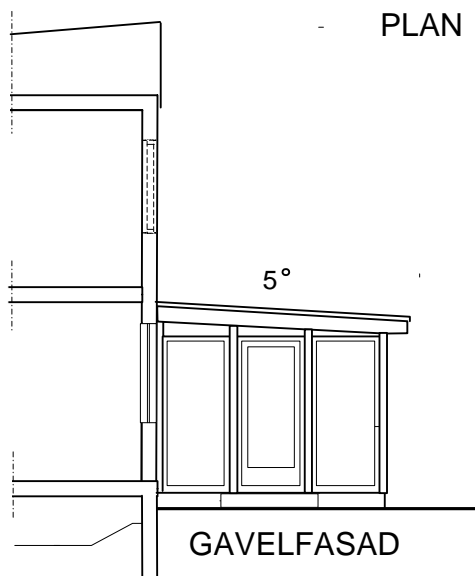

SKISS 20120315

SALEMS KOMMUN

HUSTYP S2 INGLASAT UTERUM VID SOVRUM

FASTIGHET:

PLAN, FASADER

ADRESS:

SKALA 1:100

DATUM:

S2-2

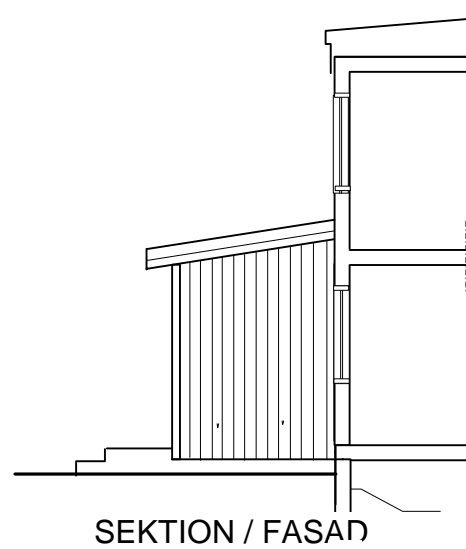
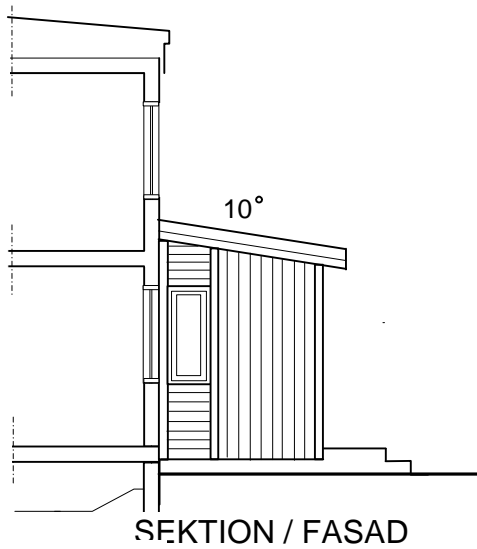
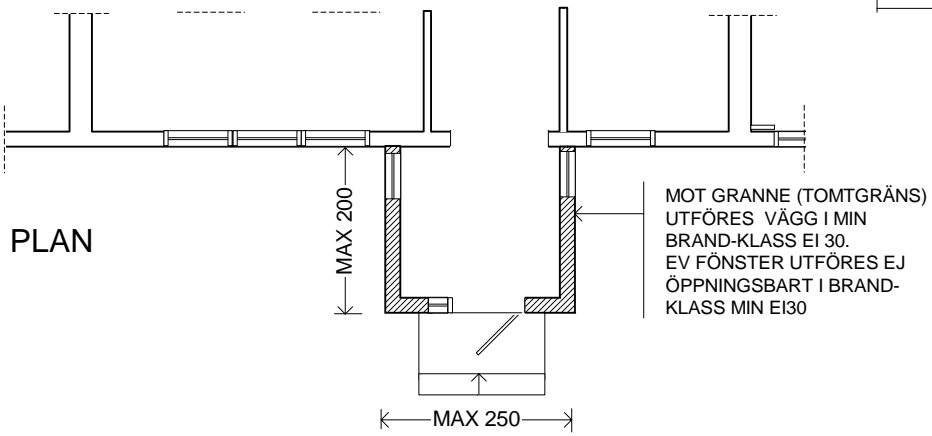

SKISS 20110418

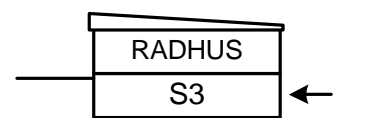

SALEMS KOMMUN

HUSTYP S3

FÖRSTUKVIST PULPETTAK

FASTIGHET:
ADRESS:

PLAN, FASADER
SKALA 1:100

DATUM:

S3-1

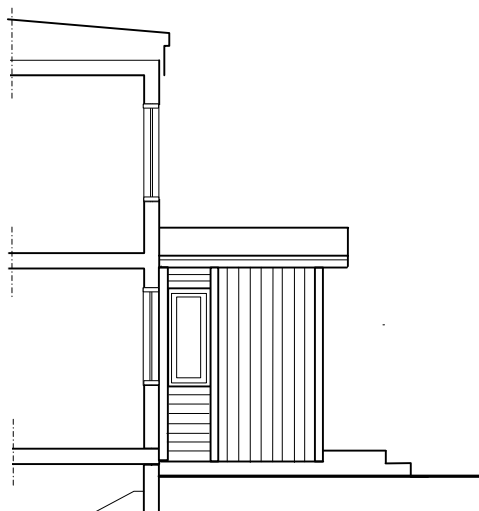
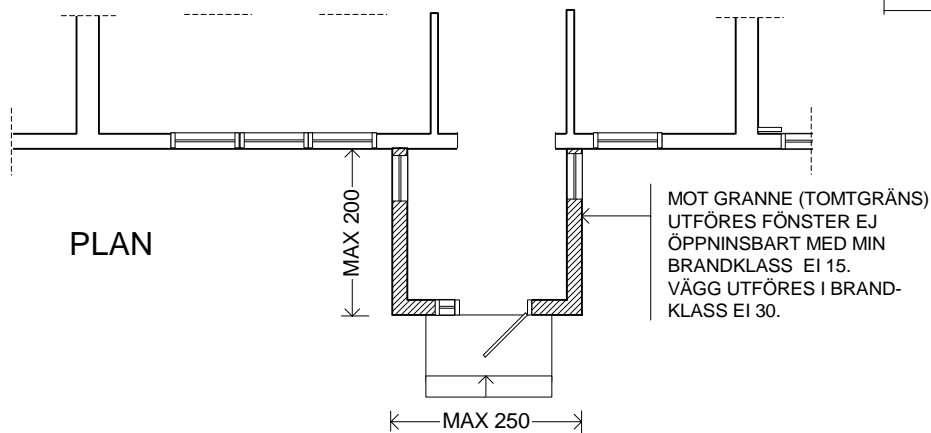

SEKTION / FASAD

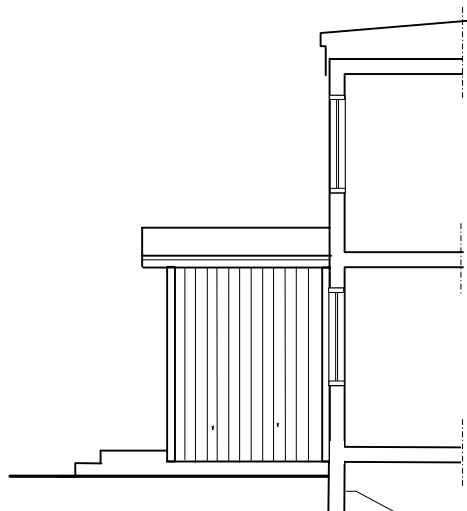

SEKTION / FASAD



FASAD

SKISS 20110418

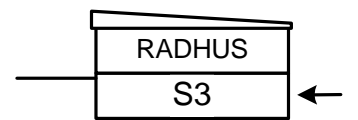

SALEMS KOMMUN

HUSTYP S3

FÖRSTUKVIST SADELTAK

FASTIGHET:

PLAN, FASADER

ADRESS:

SKALA 1:100

DATUM:

S3-2

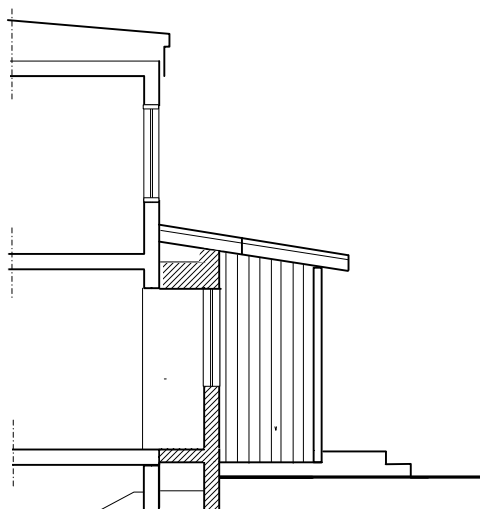
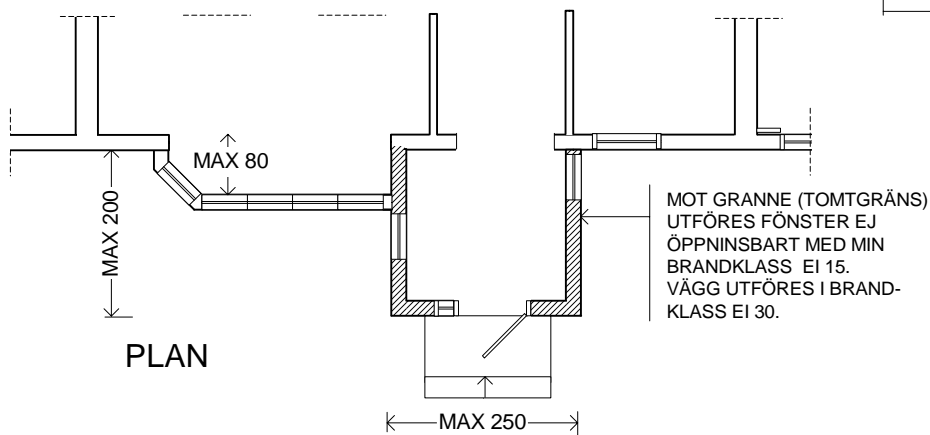

SEKTION / FASAD

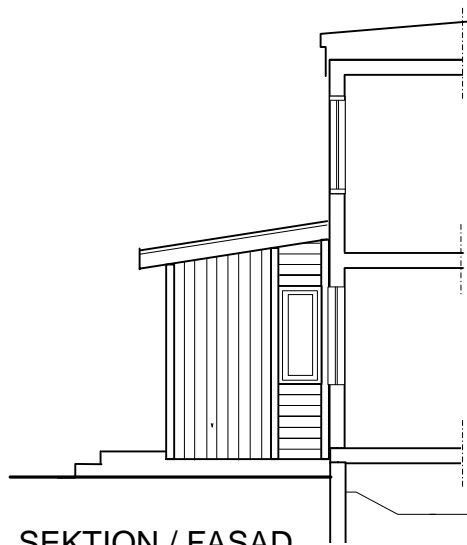

SEKTION / FASAD



FASAD

SKISS 20110418

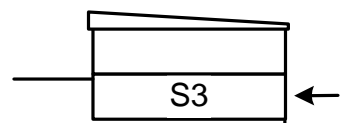

SALEMS KOMMUN

HUSTYP S3

FASTIGHET:
 ADRESS:

PLAN, FASADER
 SKALA 1:100

DATUM:

S3-3

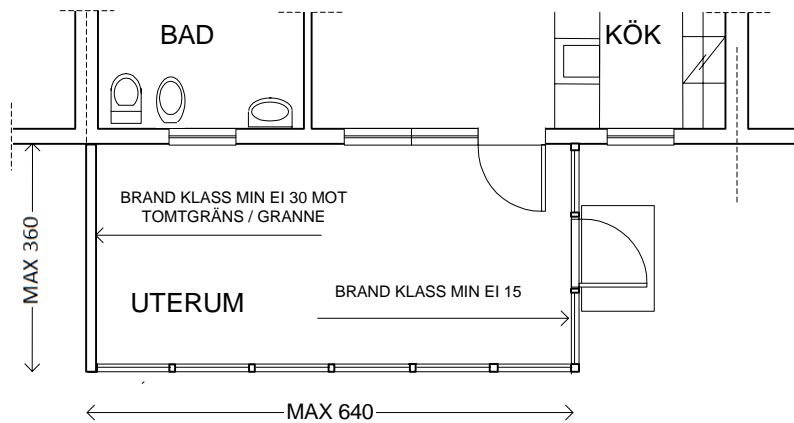

PLAN

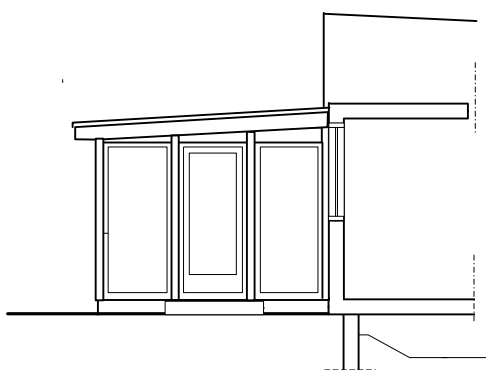

SEKTION / FASAD

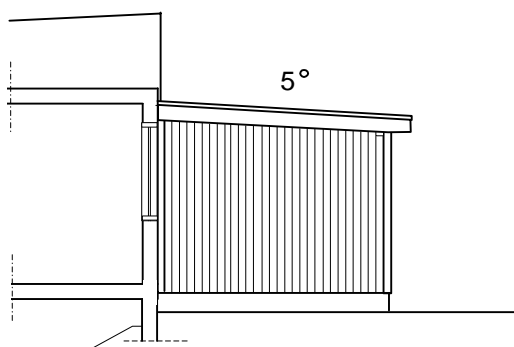

SEKTION / FASAD

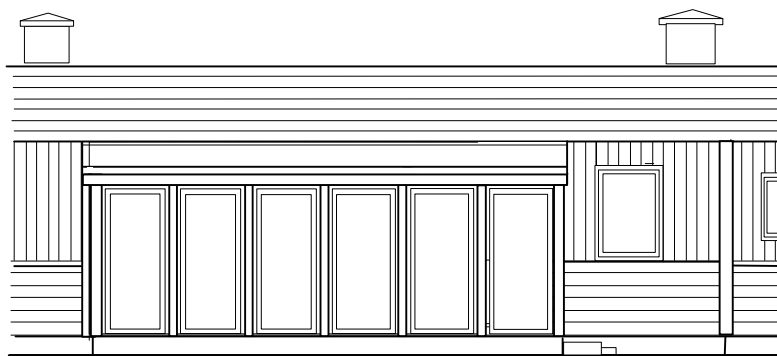

FASAD

SKISS 20110418

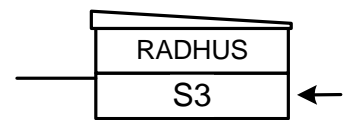

SALEMS KOMMUN

HUSTYP S3. INGLASAT UTERUM VID BADRUM

FASTIGHET:

PLAN, FASADER

ADRESS:

SKALA 1:100

DATUM:

S3-4

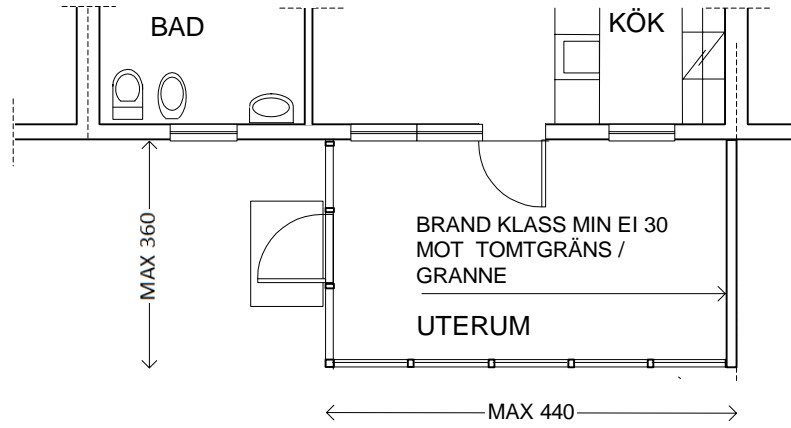

PLAN

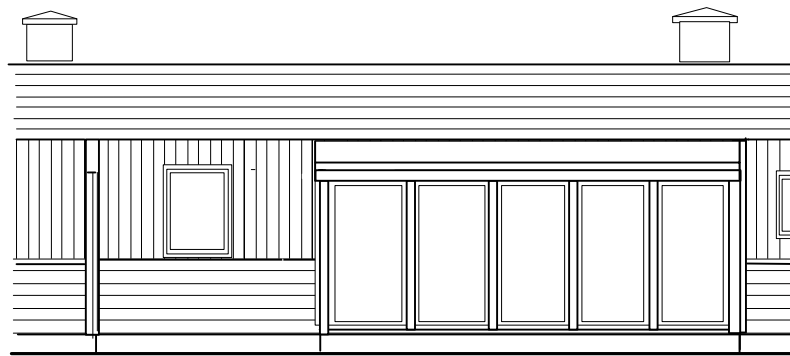
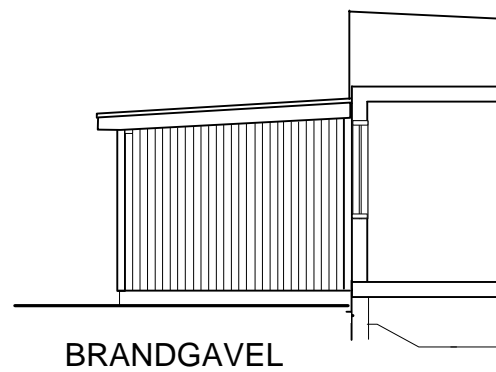
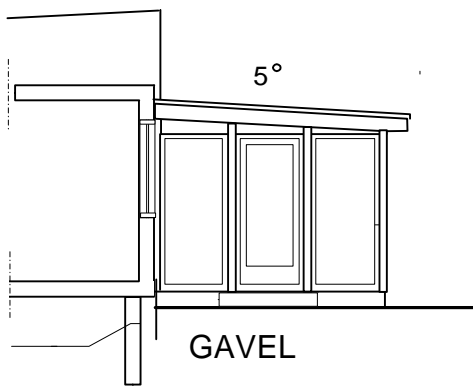

SKISS 20110418

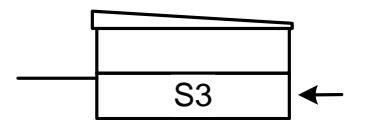

SALEMS KOMMUN

HUSTYP S3. INGLASAT UTERUM VID KÖK

FASTIGHET:

PLAN, FASADER

ADRESS:

SKALA 1:100

DATUM:

S3-5