

RITNGEN GÄLLER
I PRINCIP S1, S2
OCH S3

SKISS 20110418

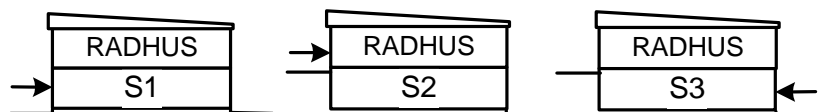

SALEMS KOMMUN

HUSTYP S1, S2 OCH S3

ENTRETAK, SADEL/
PULPET

FASTIGHET:

PLAN, FASADER

ADRESS:

SKALA 1:100

DATUM:

K3

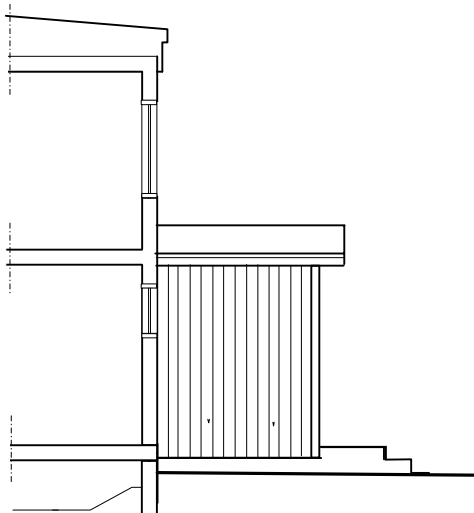
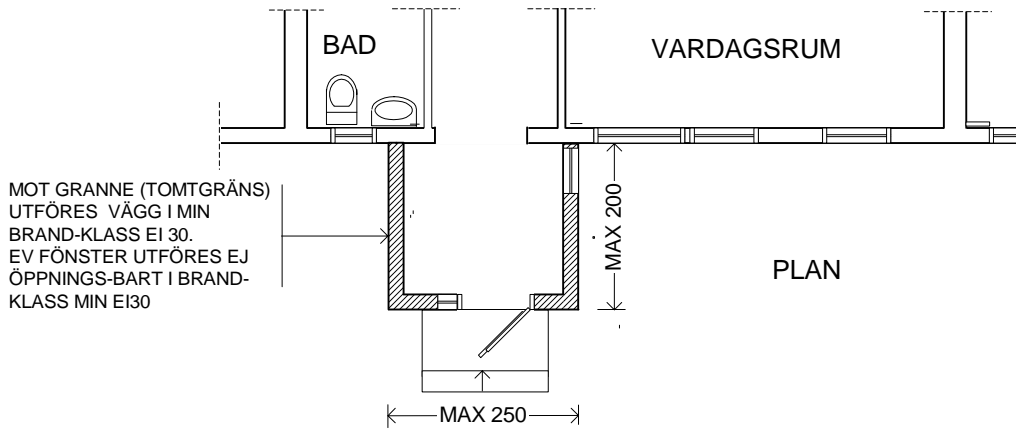

SEKTION/FASAD

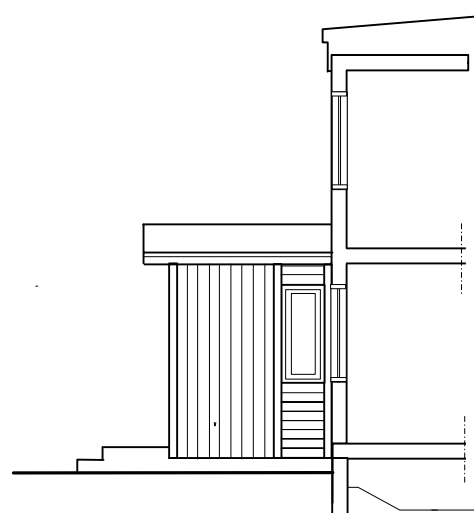

SEKTION/FASAD



FASAD

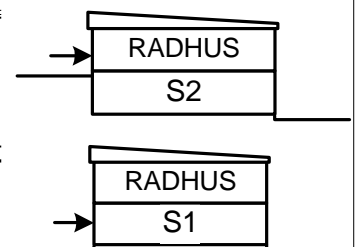

SKISS 20110418

SALEMS KOMMUN

HUSTYP S1, S2

FÖRSTUKVIST MED SADELTAK

FASTIGHET:

PLAN, FASADER

ADRESS:

SKALA 1:100

DATUM:

K4

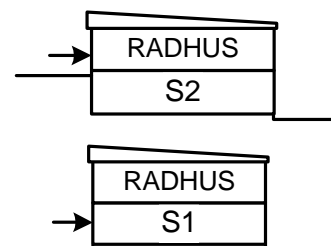
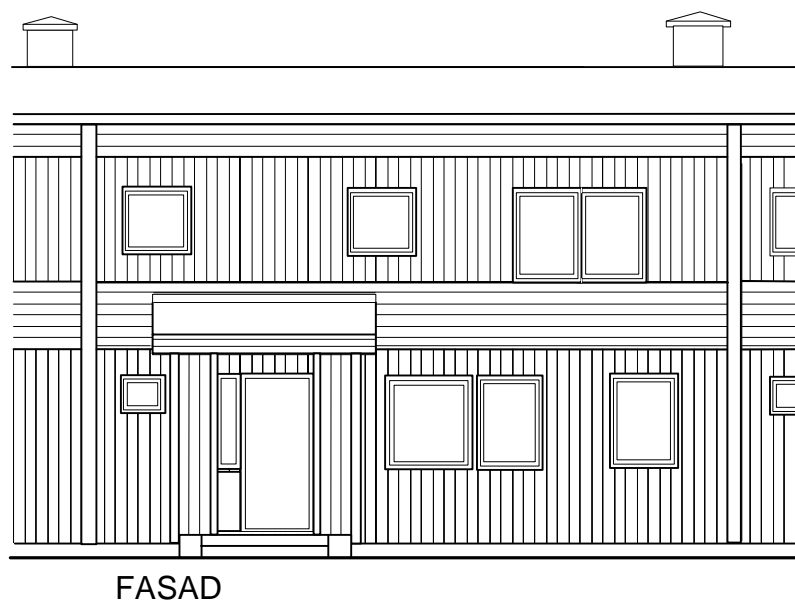
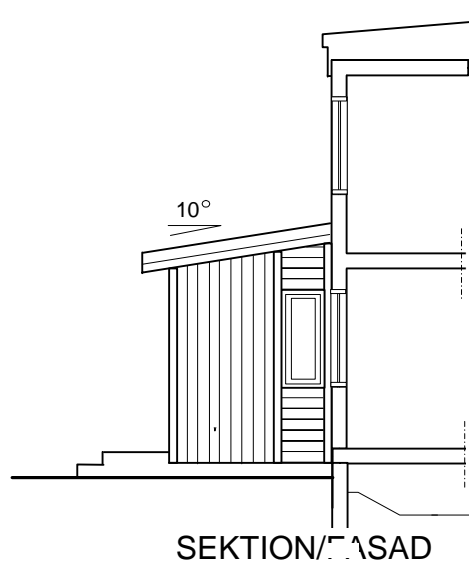
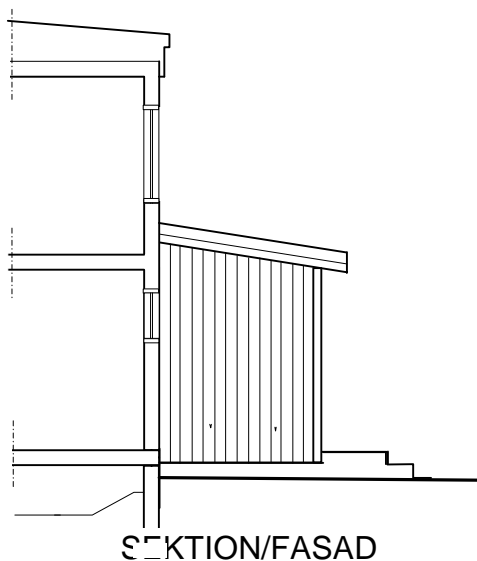
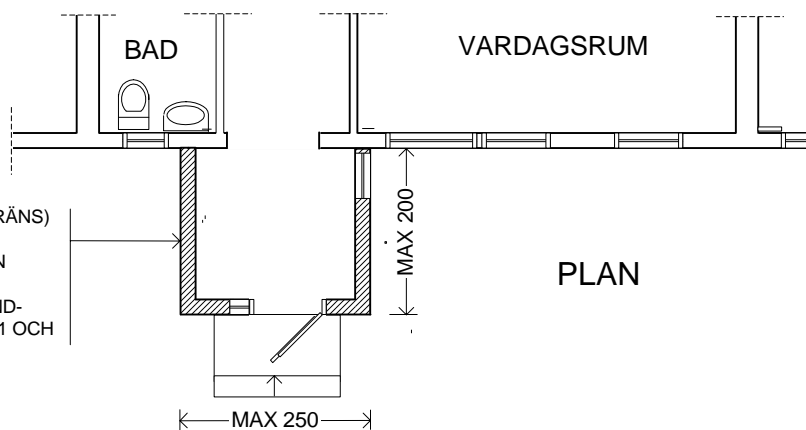

SKISS 20110418

SALEMS KOMMUN

HUSTYP S1, S2

FÖRSTUKVIST PULPETTAK

FASTIGHET:

PLAN, FASADER

ADRESS:

SKALA 1:100

DATUM:

K5

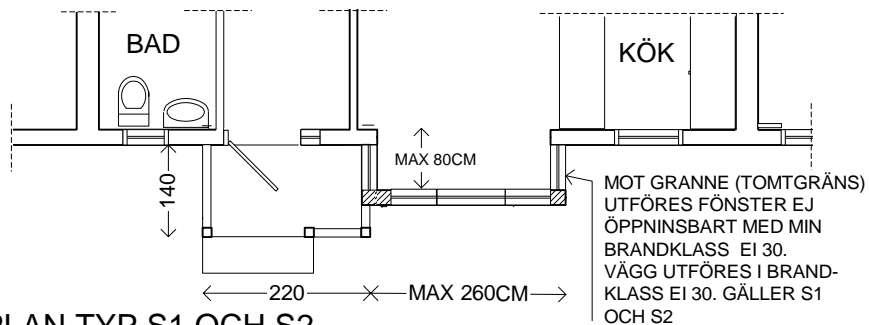

PLAN TYP S1 OCH S2
SAMT I PRINCIP S3



FASAD TYP S3

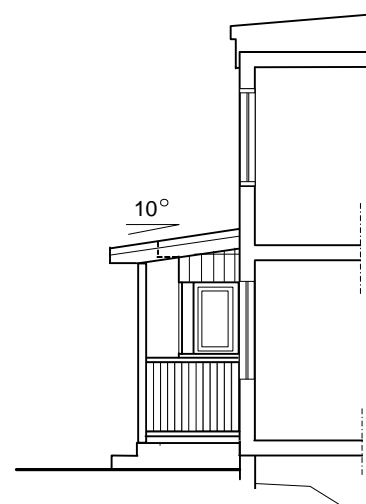

SEKTION/FASAD



FASAD TYP S1 SAMT I PRINCIP S2

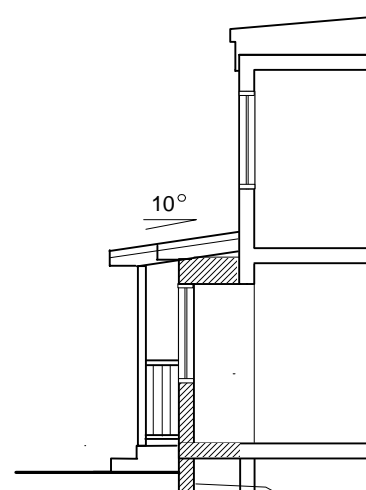

SEKTION/FASAD

SKISS 20110418

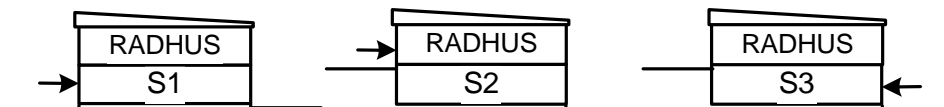

SALEMS KOMMUN

HUSTYP S1, S2, S3

ENTRETAK OCH BURSFRÅK MED
PULPETTAK

FASTIGHET:

PLAN, FASADER

ADRESS:

SKALA 1:100

DATUM:

K6

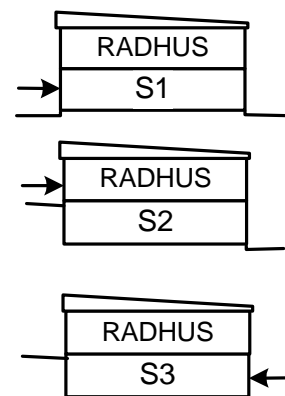
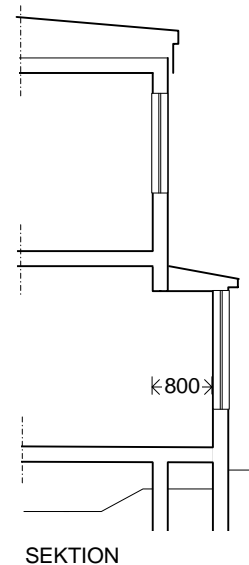
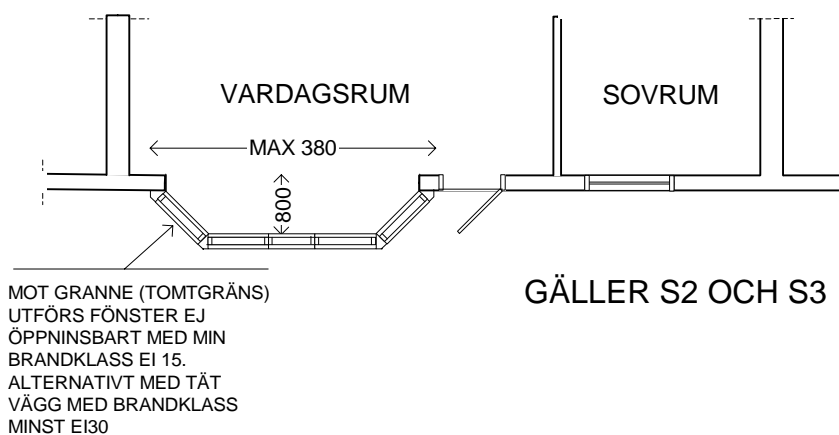
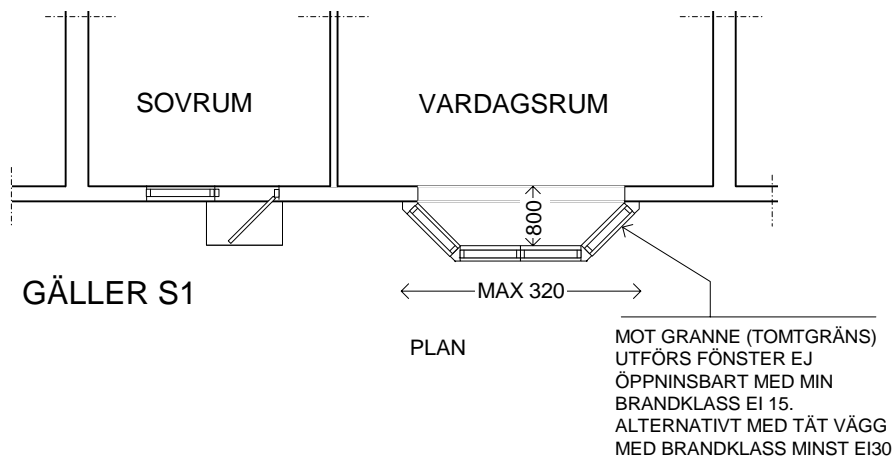

SKISS 20110418

SALEMS KOMMUN

HUSTYP S1, S2, S3 BURSPRÅK PÅ BAKSIDAN

FASTIGHET:

PLAN, FASADER

ADRESS:

SKALA 1:100

DATUM:

K7

BOFINKEN

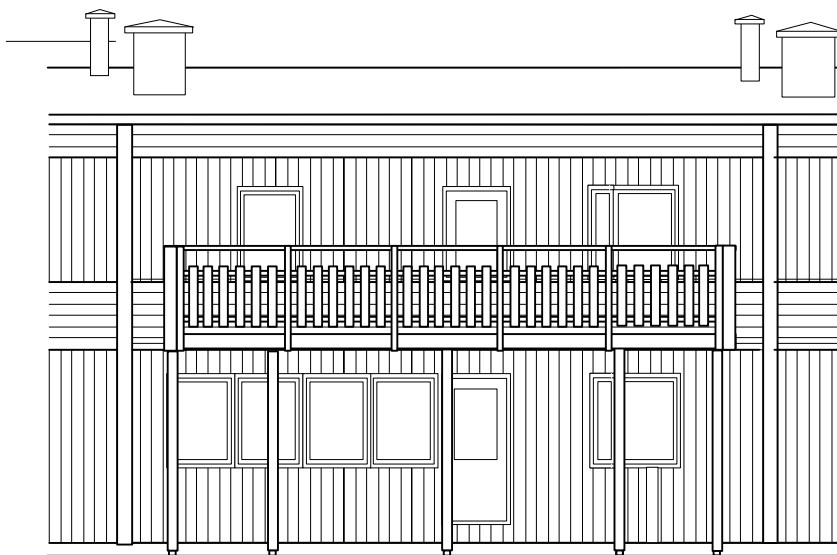
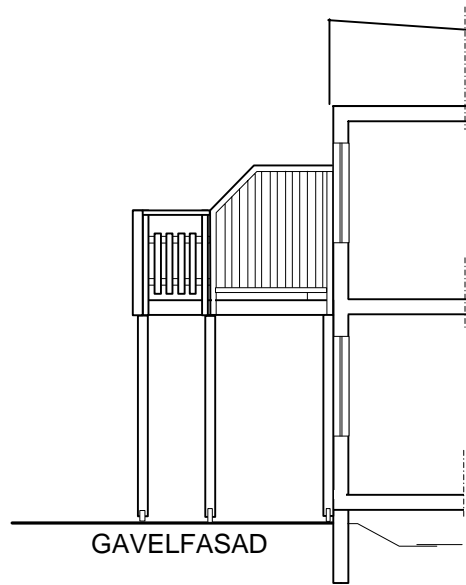
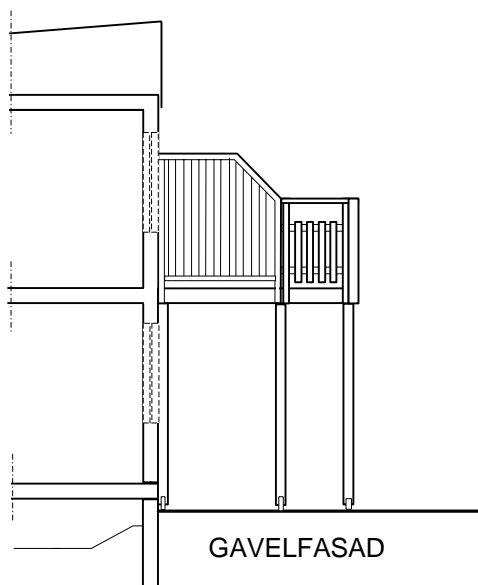
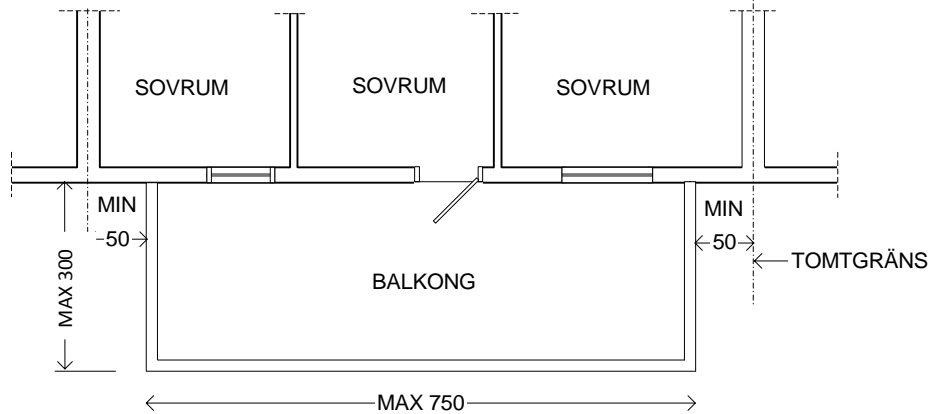

BALKONGRITNINGEN
GÄLLER I PRINCIP ALLA
TVÅVÅNINGSS FASADER FÖR
HUSTYP S1,S2 OCH S3

SKISS 20110418

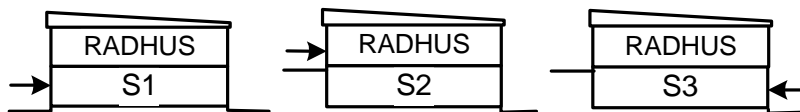

SALEMS KOMMUN

HUSTYP S1, S2, S3 BALKONG, RAKA HÖRN

FASTIGHET:
ADRESS:

PLAN, FASADER
SKALA 1:100 DATUM:

K8

BOFINKEN

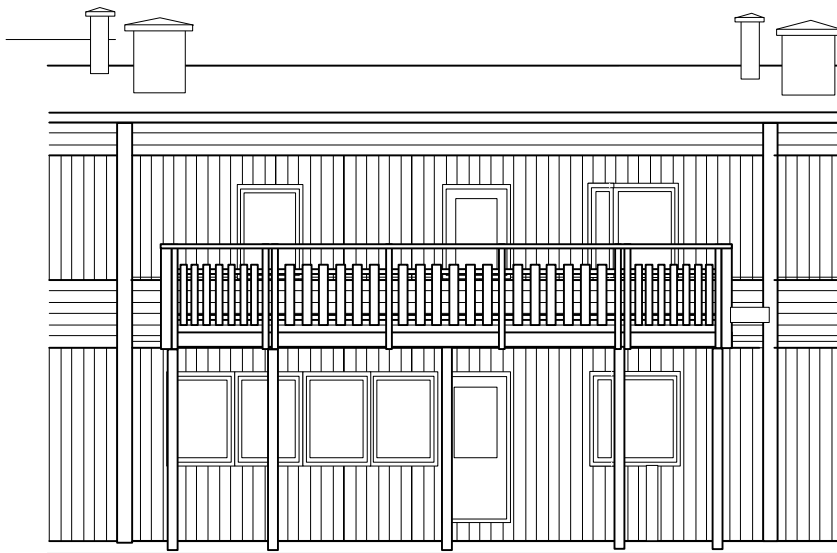
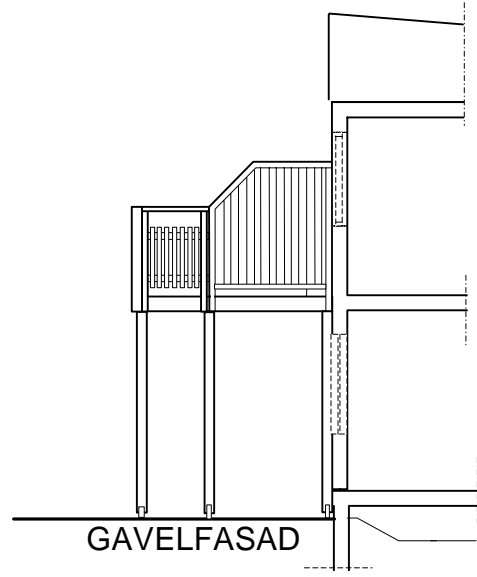
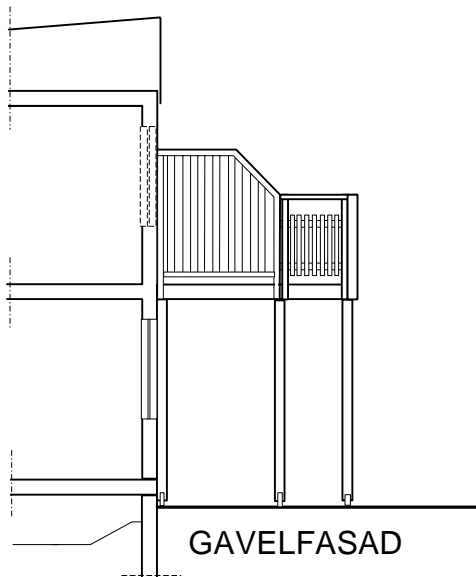
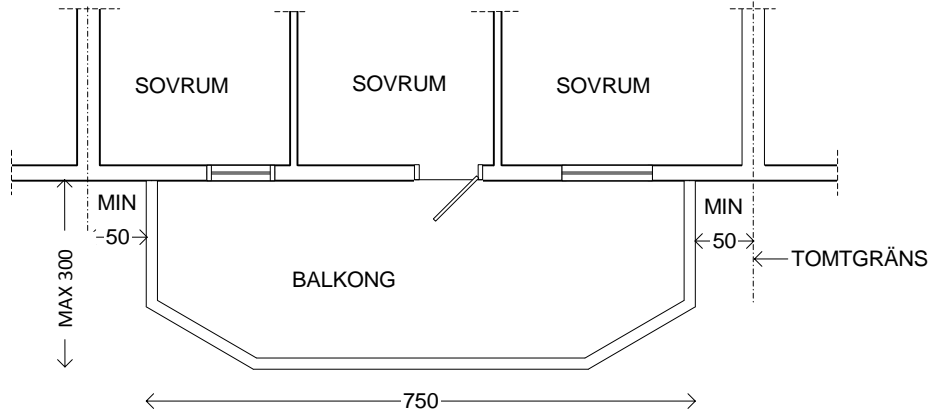

BALKONGRITNINGEN
GÄLLER I PRINCIP ALLA
TVÅVÅNINGS FASADER FÖR
HUSTYP S1,S2 OCH S3

SKISS 20110418

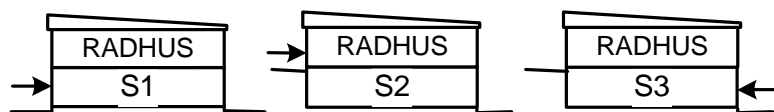

SALEMS KOMMUN

HUSTYP S1, S2, S3 BALKONG, FASADE HÖRN

FASTIGHET:

PLAN, FASADER

ADRESS:

SKALA 1:100

DATUM:

K9

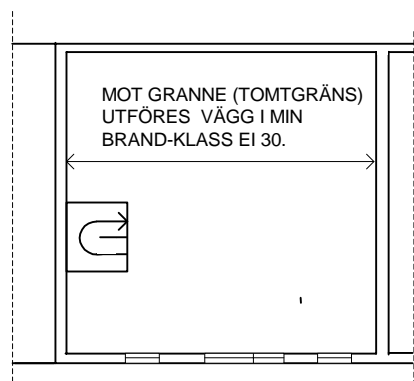

PÅBYGD VÅNINGSPÅN
SKALA 1:200

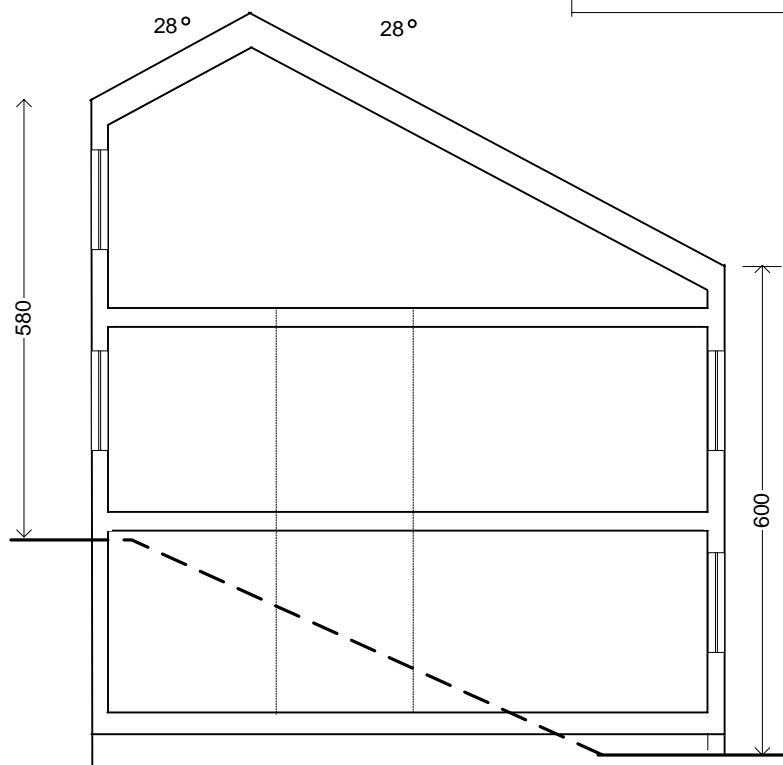

NY FASAD SKALA 1:100

SKISS 20110418

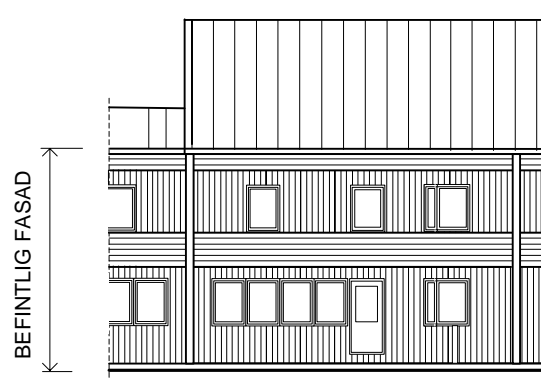

BEFINTLIG FASAD

SKALA 1:200

SKISSRITNINGEN VISAR
TYP S2 MEN GÄLLER I
PRINCIP ÄVEN TYP S3

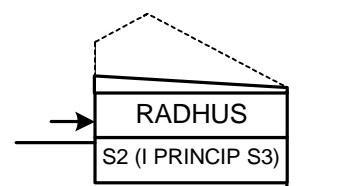

SALEMS KOMMUN

HUSTYP S2, PÅBYGGNAD VIND, SADELTAK.

FASTIGHET:

PLAN, FASADER

ADRESS:

SKALA 1:100

DATUM:

K10

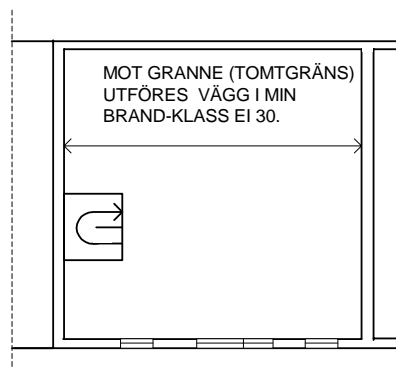

PÅBYGD VÅNINGSPÅN
SKALA 1:200

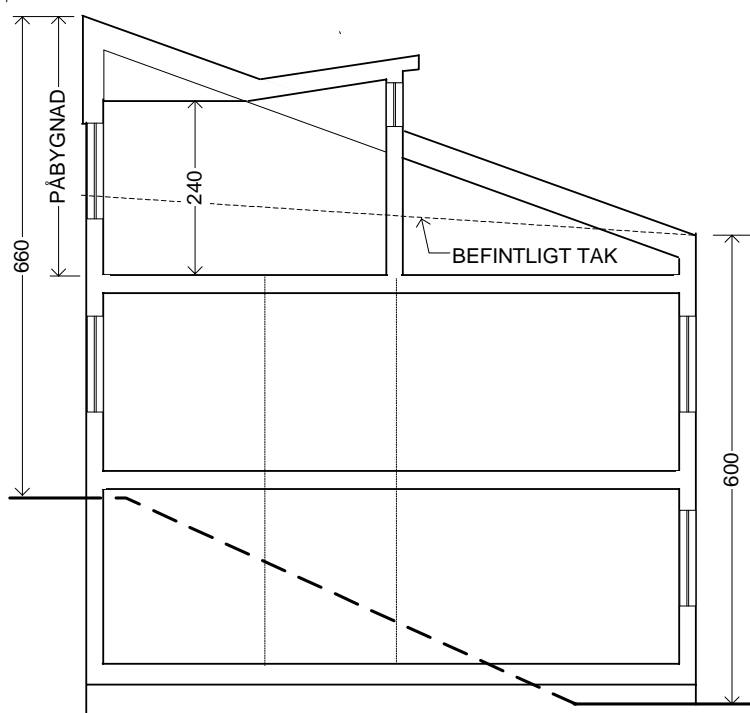

NY FASAD SKALA 1:100

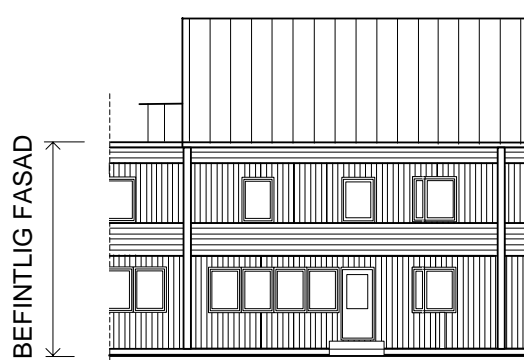

SKALA 1:200

RITNINGEN VISAR TYP
S2 MEN GÅLLER I
PRINCIP ÄVEN TYP S3

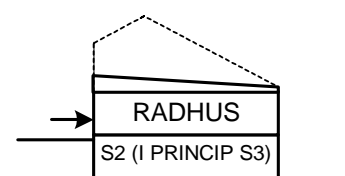

SKISS 20110418

SALEMS KOMMUN

HUSTYP S2, S3. PÅBYGGNAD VIND, PULPETTAK.

FASTIGHET:

PLAN, FASADER

ADRESS:

SKALA 1:100

DATUM:

K-11

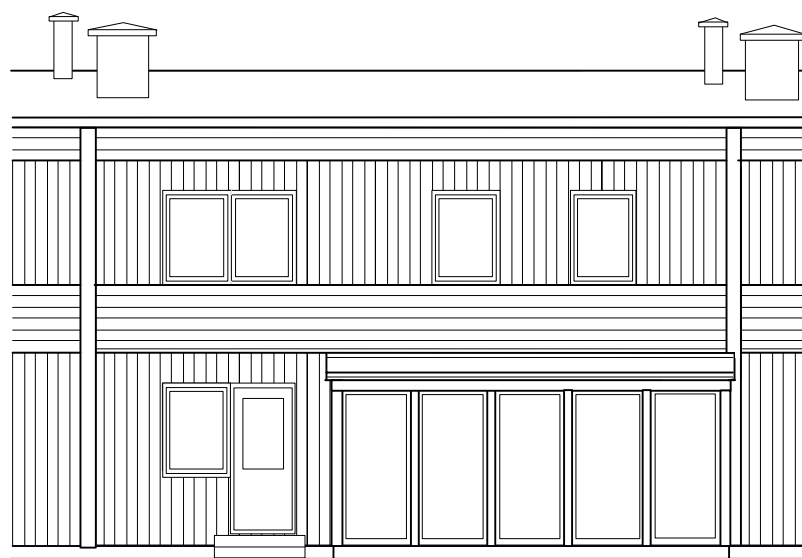
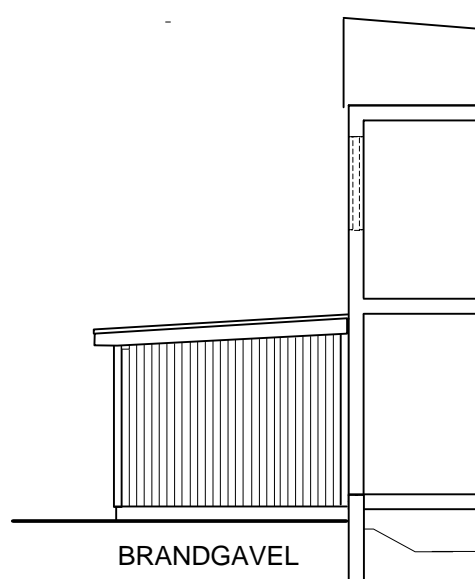
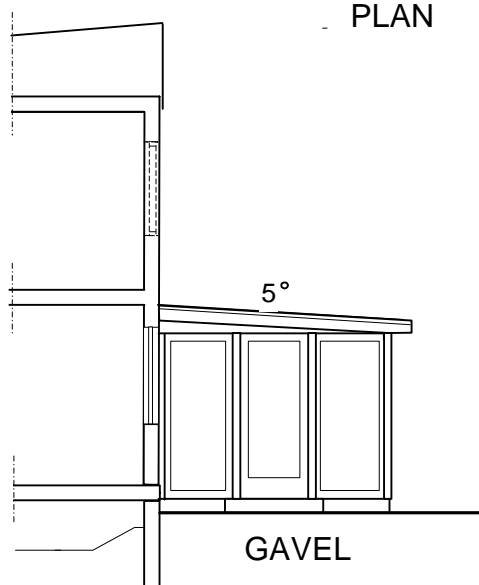
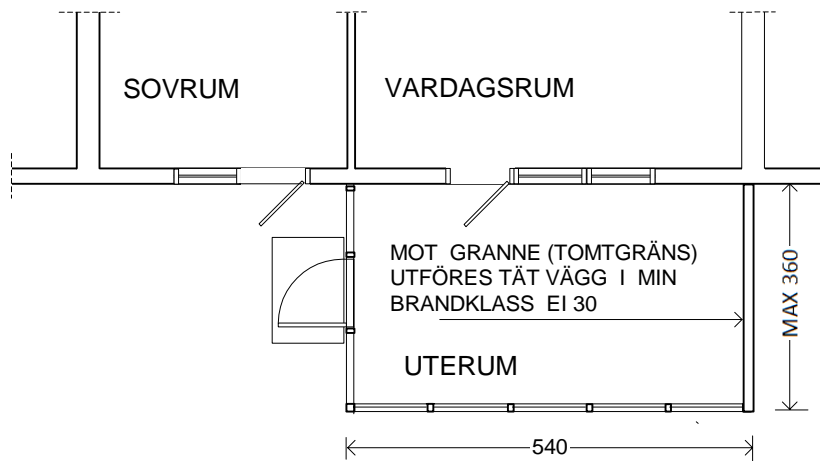

FASAD

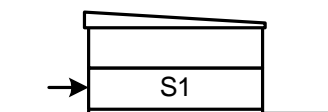

SKISS 20110418

SALEMS KOMMUN

HUSTYP S1 INGLASAT UTERUM VID VARDAGSRUM

FASTIGHET:

PLAN, FASADER

ADRESS:

SKALA 1:100

DATUM:

S1-1

BOFINKEN

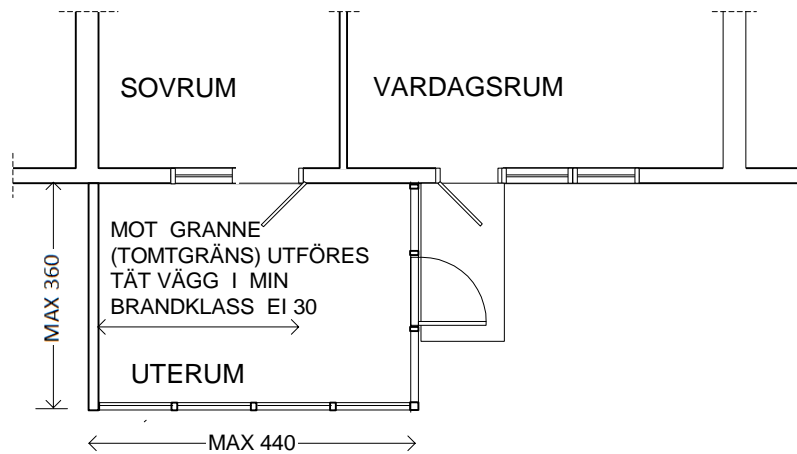

PLAN,

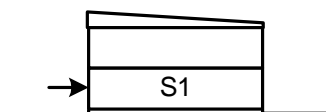
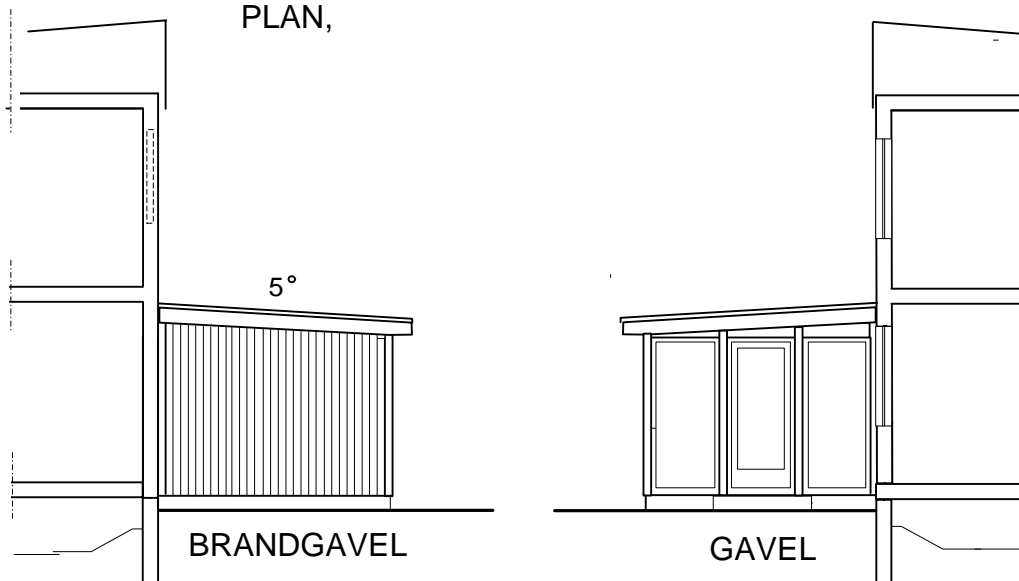

SKISS 20110418

SALEMS KOMMUN

HUSTYP S1

INGLASAT UTERUM VID SOVRUM

FASTIGHET:

PLAN, FASADER

ADRESS:

SKALA 1:100

DATUM:

S1-2

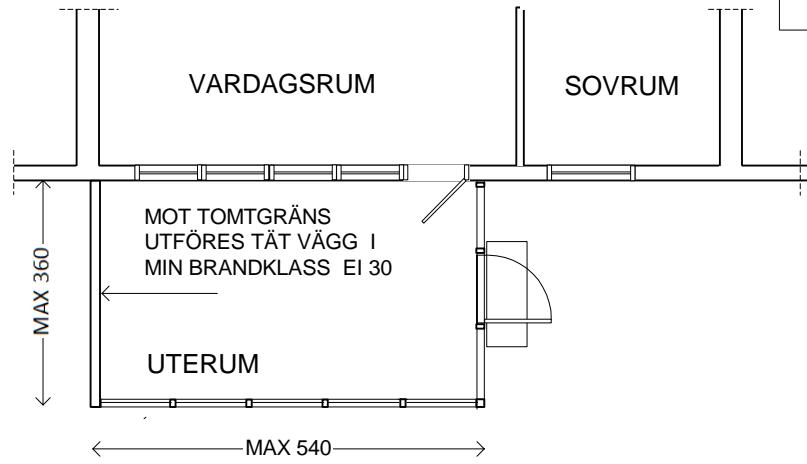

PLAN

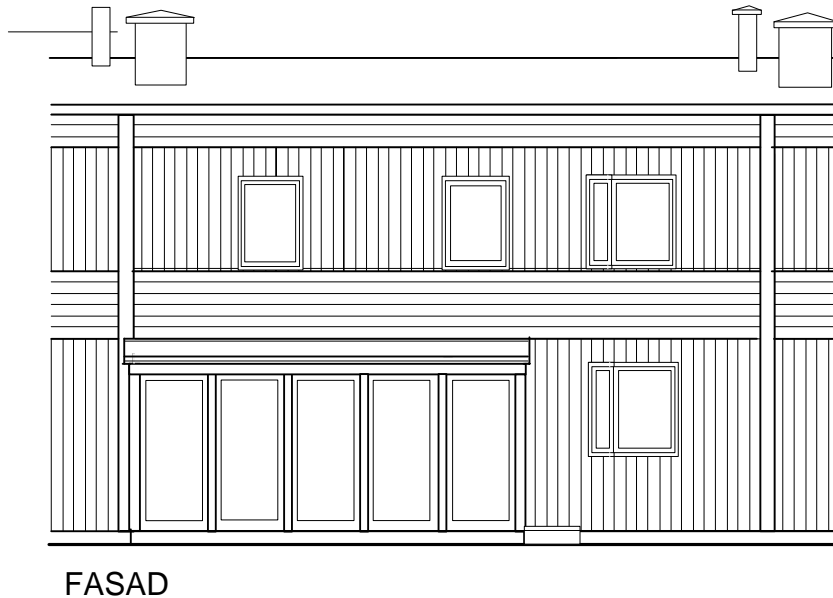
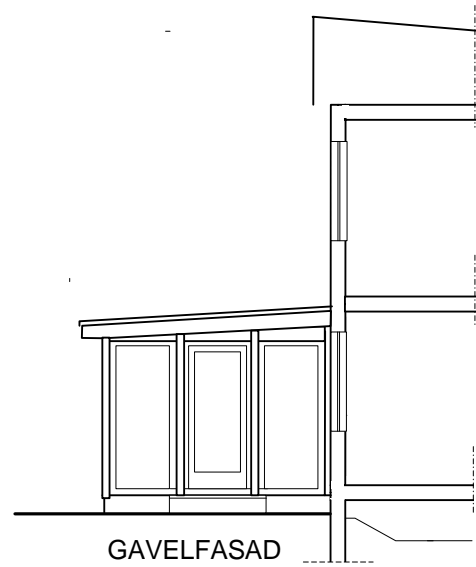
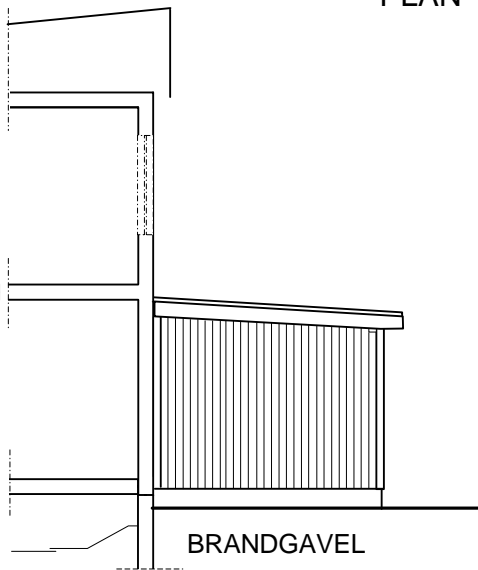

SKISS 2012015

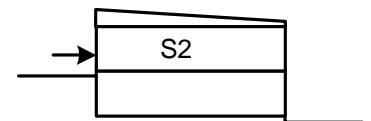

SALEMS KOMMUN

HUSTYP S2 INGLASAT UTERUM VID VARDAGSRUM

FASTIGHET:

PLAN, FASADER

ADRESS:

SKALA 1:100

DATUM:

S2-1

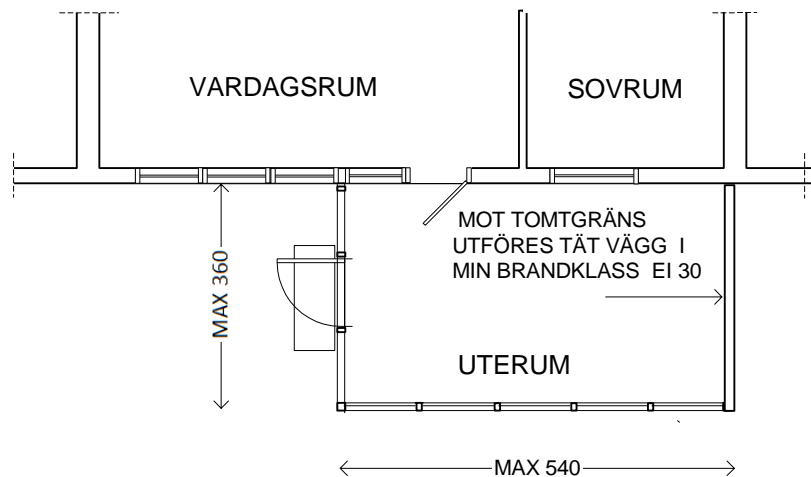

PLAN

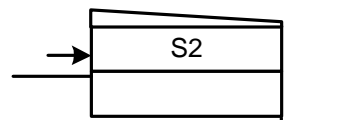
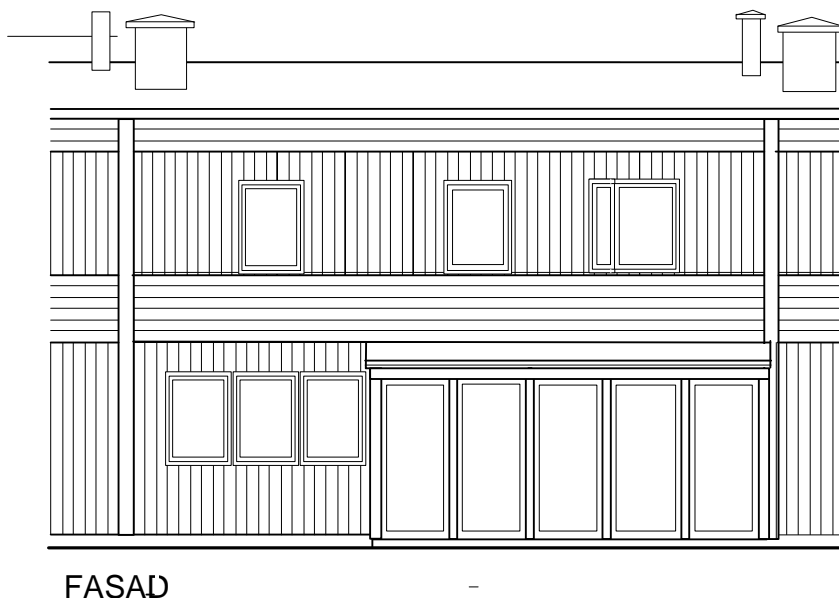
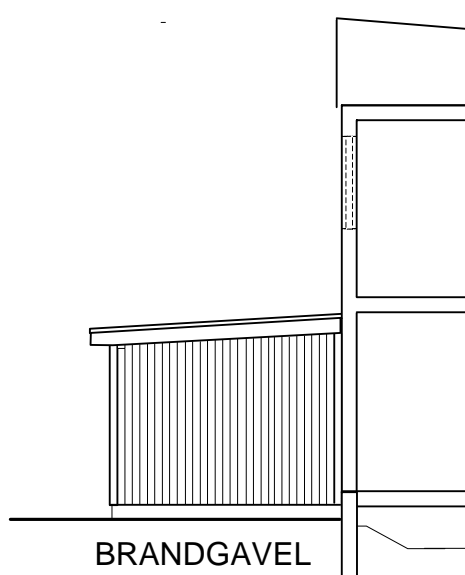
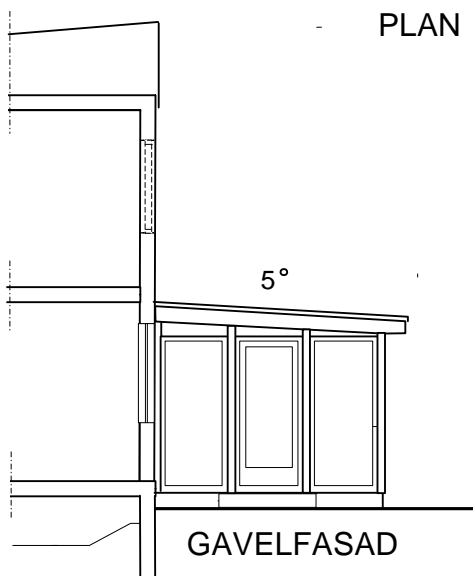

SKISS 20120315

SALEMS KOMMUN

HUSTYP S2 INGLASAT UTERUM VID SOVRUM

FASTIGHET:

PLAN, FASADER

ADRESS:

SKALA 1:100

DATUM:

S2-2

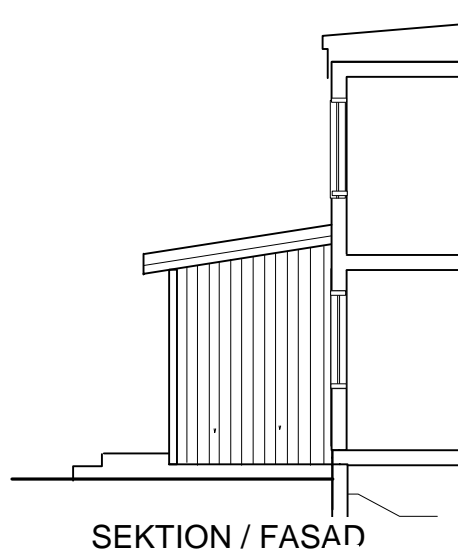
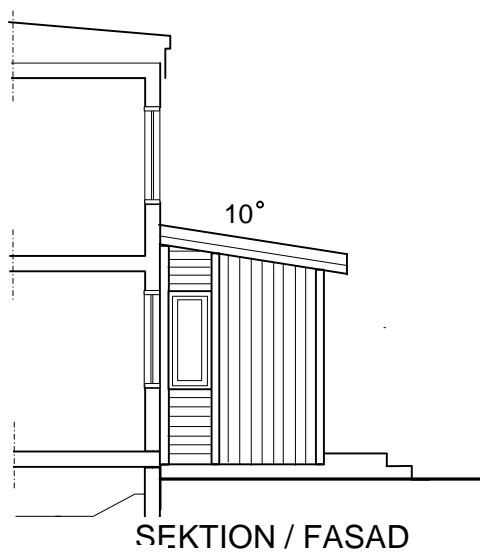
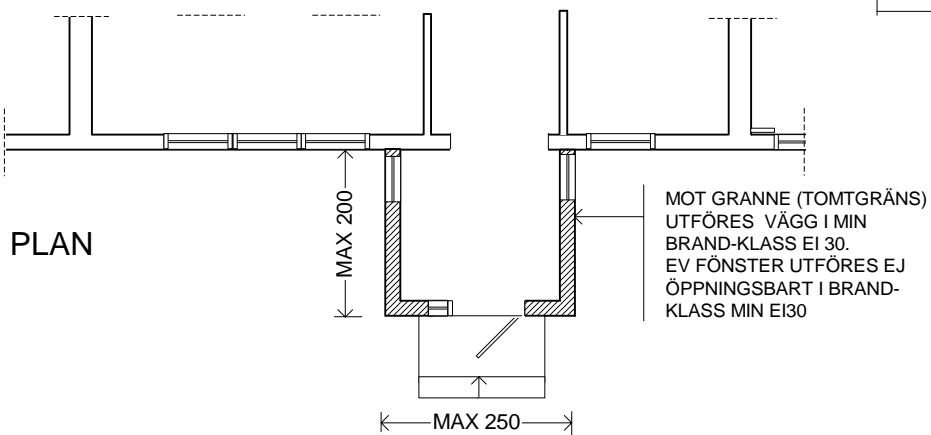

SKISS 20110418

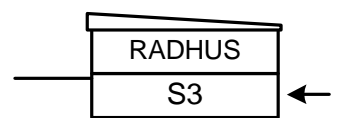

SALEMS KOMMUN

HUSTYP S3

FÖRSTUKVIST PULPETTAK

FASTIGHET:
 ADRESS:

PLAN, FASADER
 SKALA 1:100

DATUM:

S3-1

PLAN

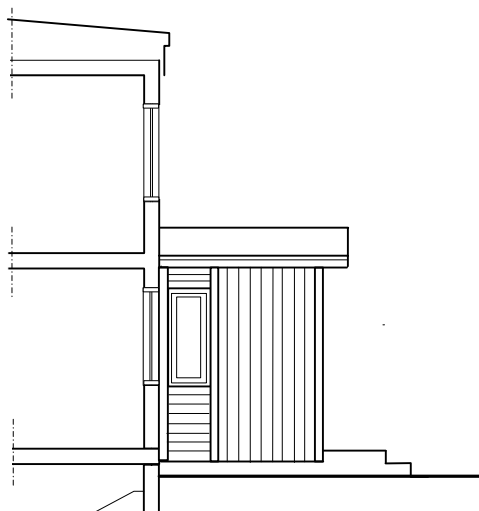
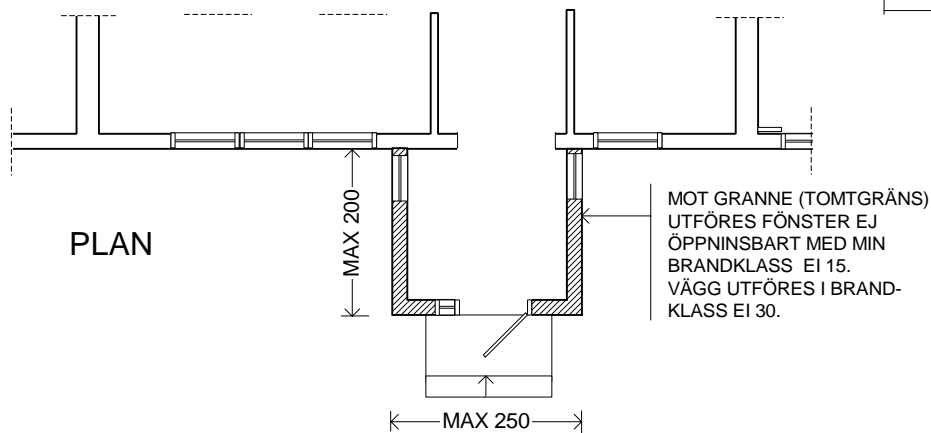

SEKTION / FASAD

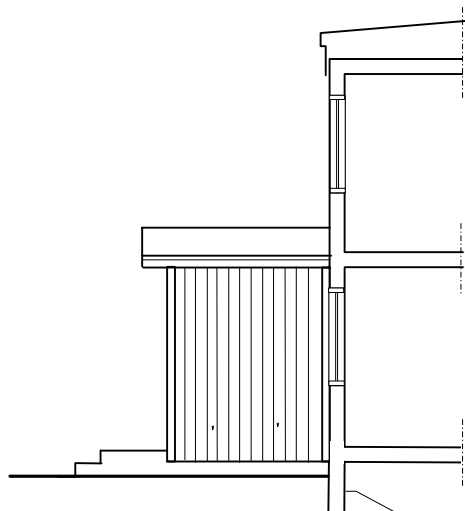

SEKTION / FASAD

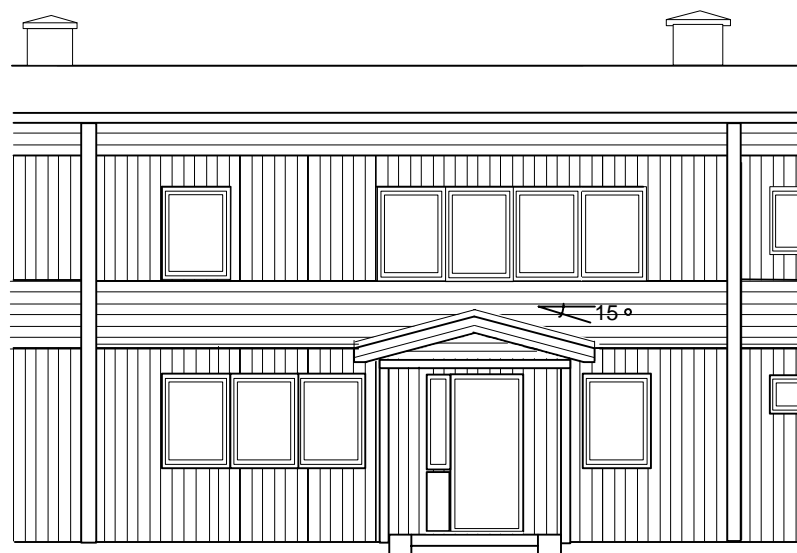

FASAD

SKISS 20110418

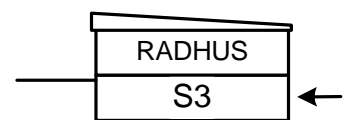

SALEMS KOMMUN

HUSTYP S3

FÖRSTUKVIST SADELTAK

FASTIGHET:

PLAN, FASADER

ADRESS:

SKALA 1:100

DATUM:

S3-2

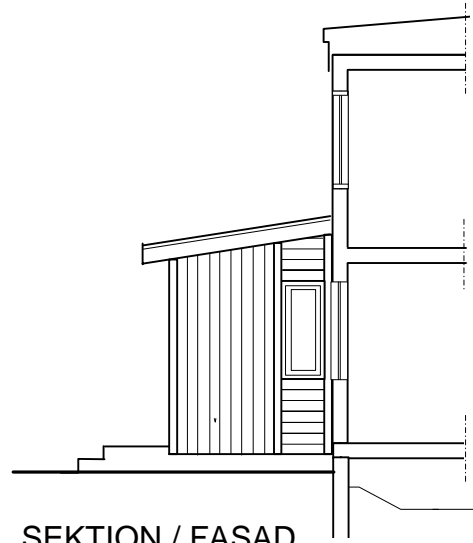
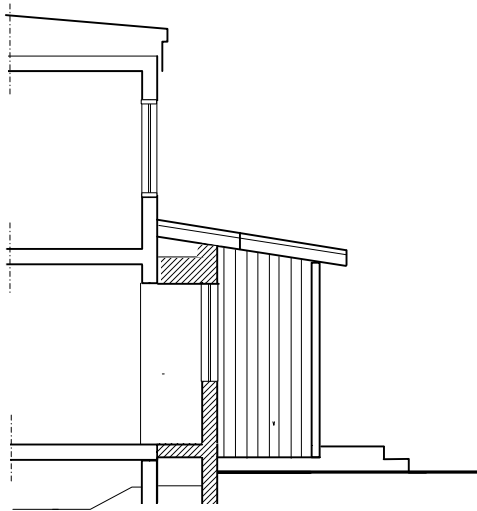
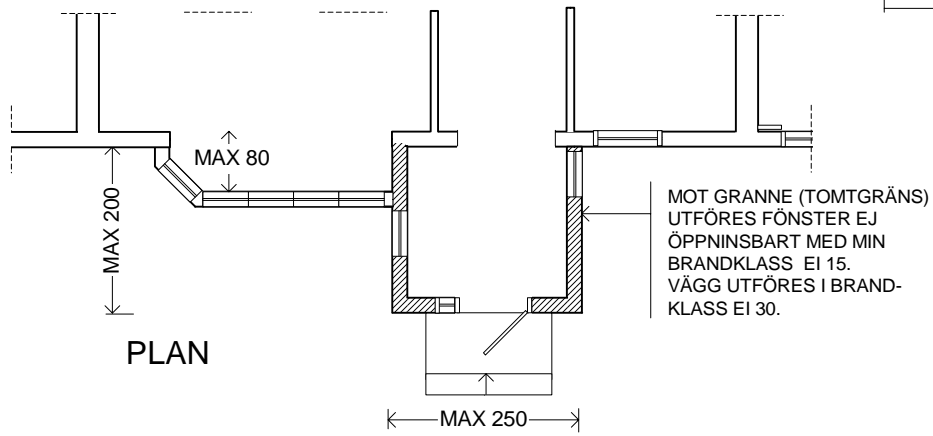

SKISS 20110418

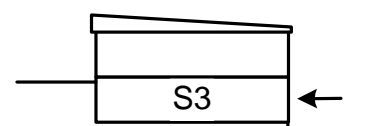

SALEMS KOMMUN

HUSTYP S3

FASTIGHET:

PLAN, FASADER

ADRESS:

SKALA 1:100

DATUM:

S3-3

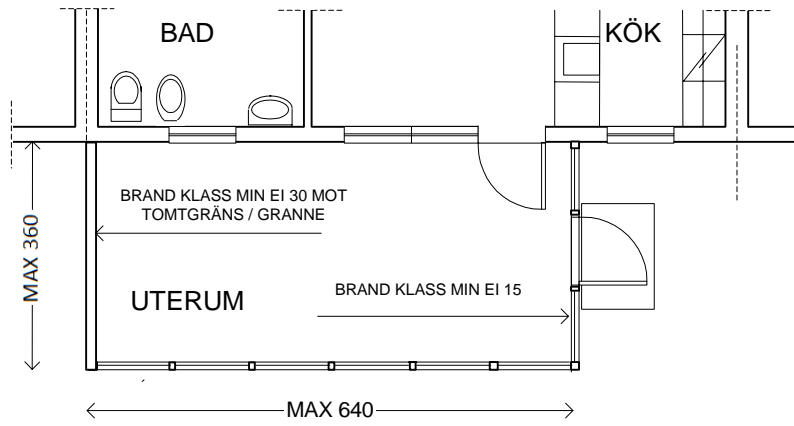

PLAN

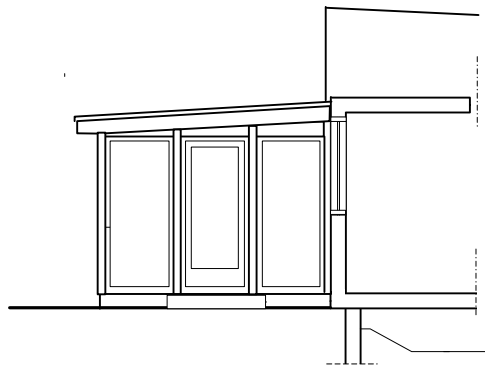

SEKTION / FASAD

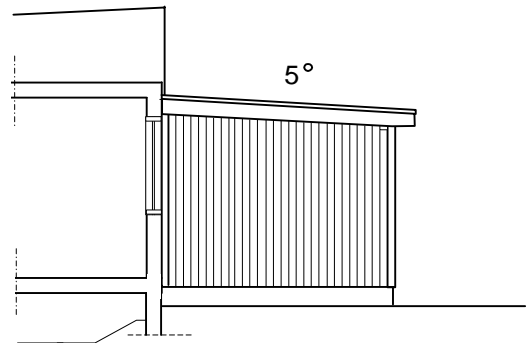

SEKTION / FASAD

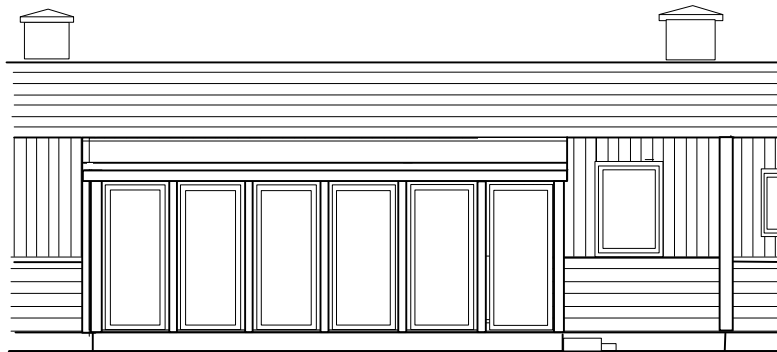

FASAD

SKISS 20110418

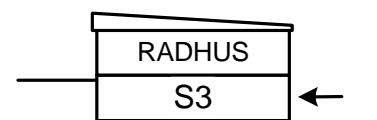

SALEMS KOMMUN

HUSTYP S3. INGLASAT UTERUM VID BADRUM

FASTIGHET:

PLAN, FASADER

ADRESS:

SKALA 1:100

DATUM:

S3-4

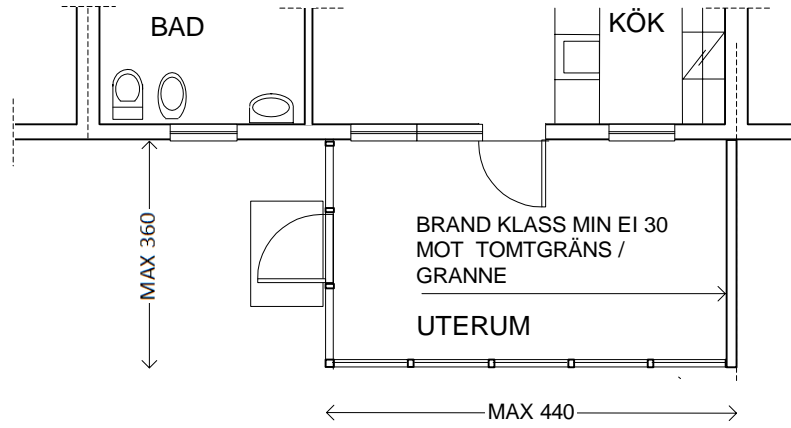

PLAN

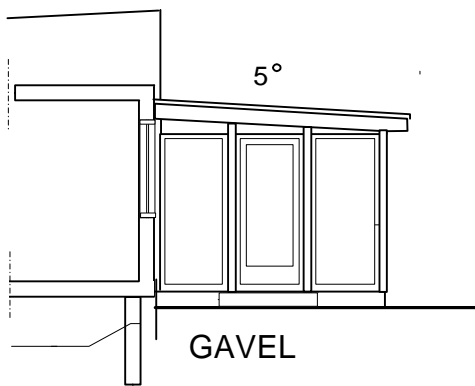

GAVEL

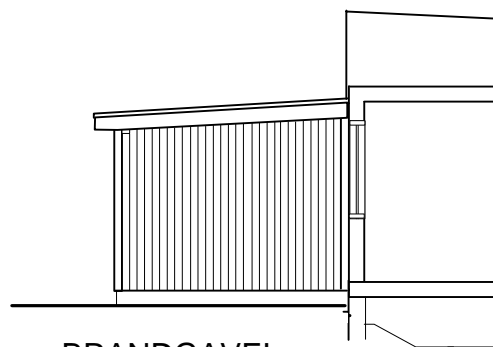

BRANDGAVEL

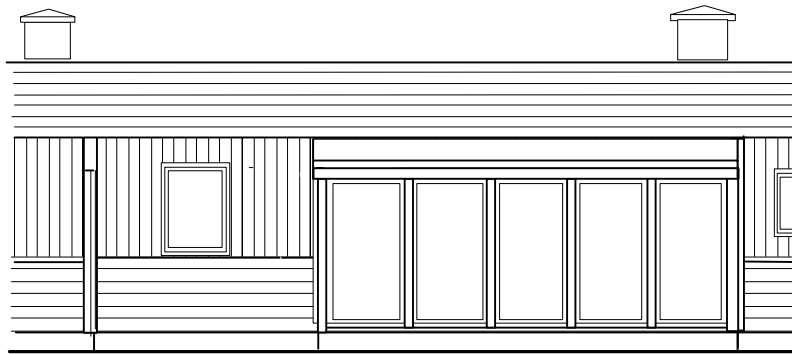

FASAD

SKISS 20110418

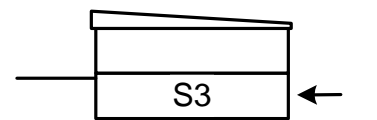

SALEMS KOMMUN

HUSTYP S3.

INGLASAT UTERUM VID KÖK

FASTIGHET:

PLAN, FASADER

ADRESS:

SKALA 1:100

DATUM:

S3-5